



Patentes y modelos de utilidad en Alemania: aspectos legales, prácticos y estratégicos a la vista del UPC.

Lunes de Patentes, 29.05.2023

Mario Araujo

- UPC ad portas! Possible reeinforsed role of national rights.
- Germany is usually most important European market.
- Germany is main patent litigation scenario in Europe (>80%):
 - Very experienced and specialized courts
 - Quick and predictable decisions, tones of case law
 - Relatively low costs
- German patent system not as used as it could?

Different ways? Different goals?

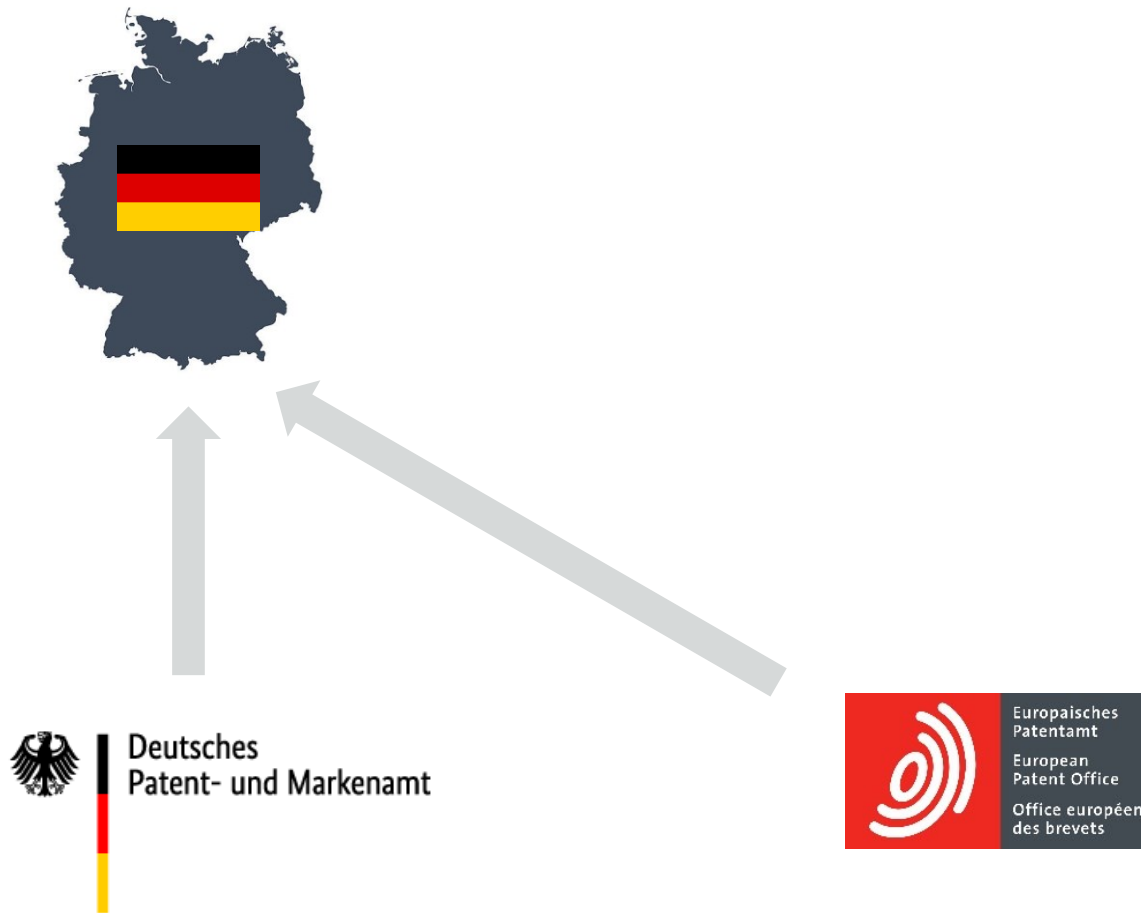

Different ways? Different goals?

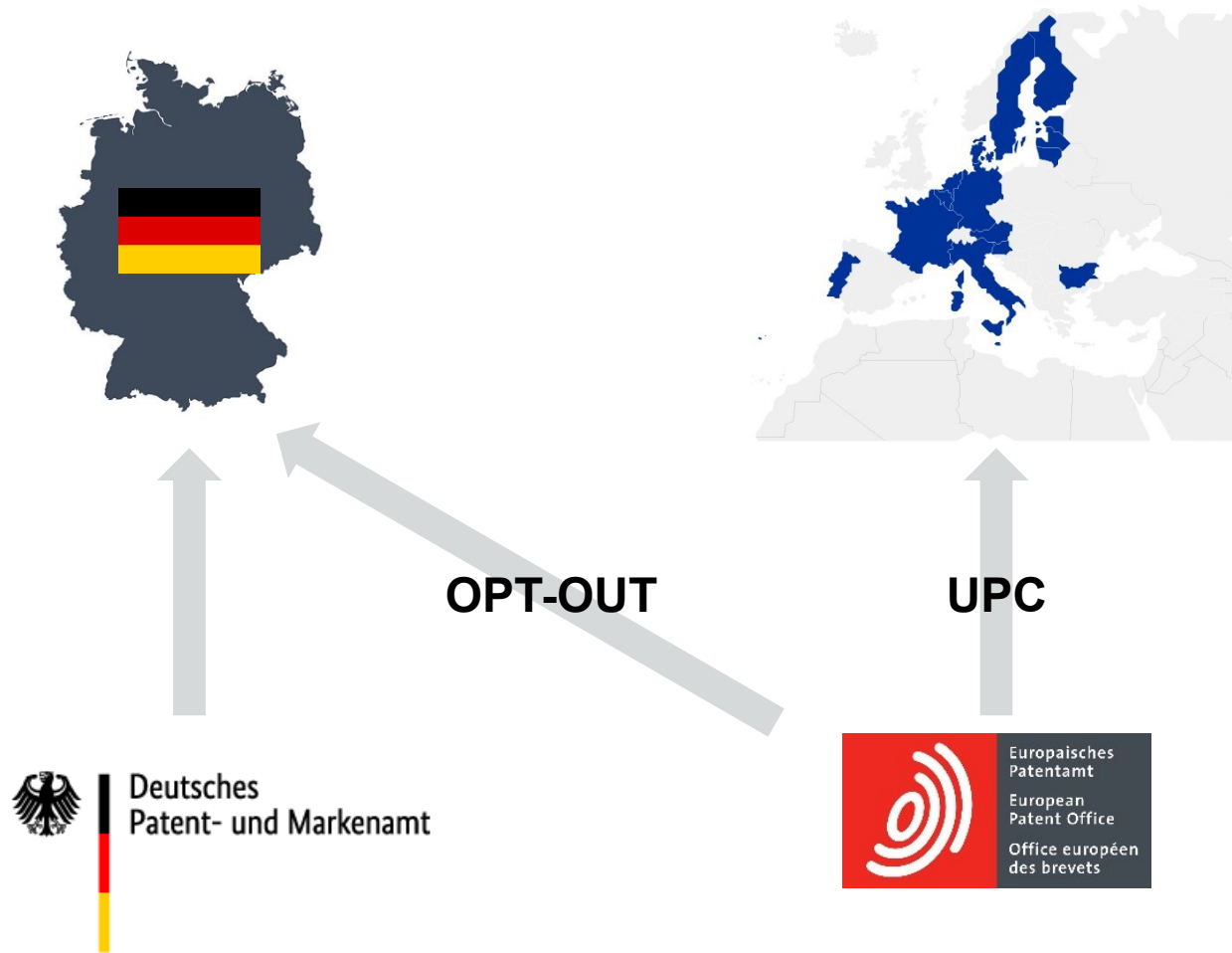

Today's take aways

- Know the German system.
- See it as the reasonable middle way (DE+UP vs EP / national)
- Fear not
- Do dare...
 - ...patenting in Germany.
 - ...using your patents in Germany.

Outline

- 1) An overview of the German patent system
 - *GPTO, BPatG, national courts*
- 2) Differences: EPO granting process vs GPTO granting process
- 3) Differences in material law: EPC vs German Patent law
- 4) German utility models:
 - *Differences over patents, use cases, branch-off*
- 5) Changes in German national patent law due to UPC and strategic considerations

1) An Overview of the German Patent System

The German patent system

Patent prosecution and validity:

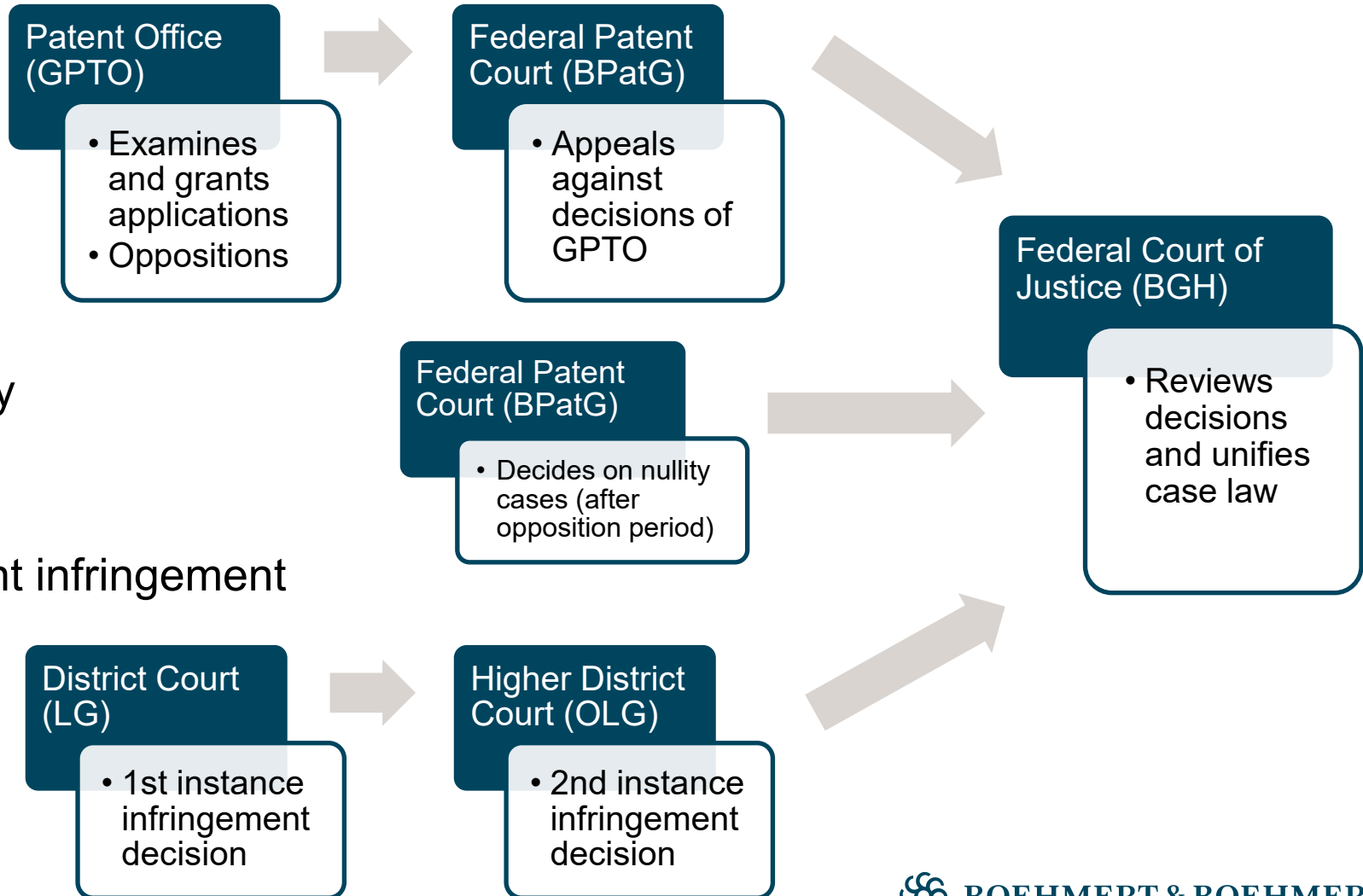

The German patent system

Patent prosecution and validity:

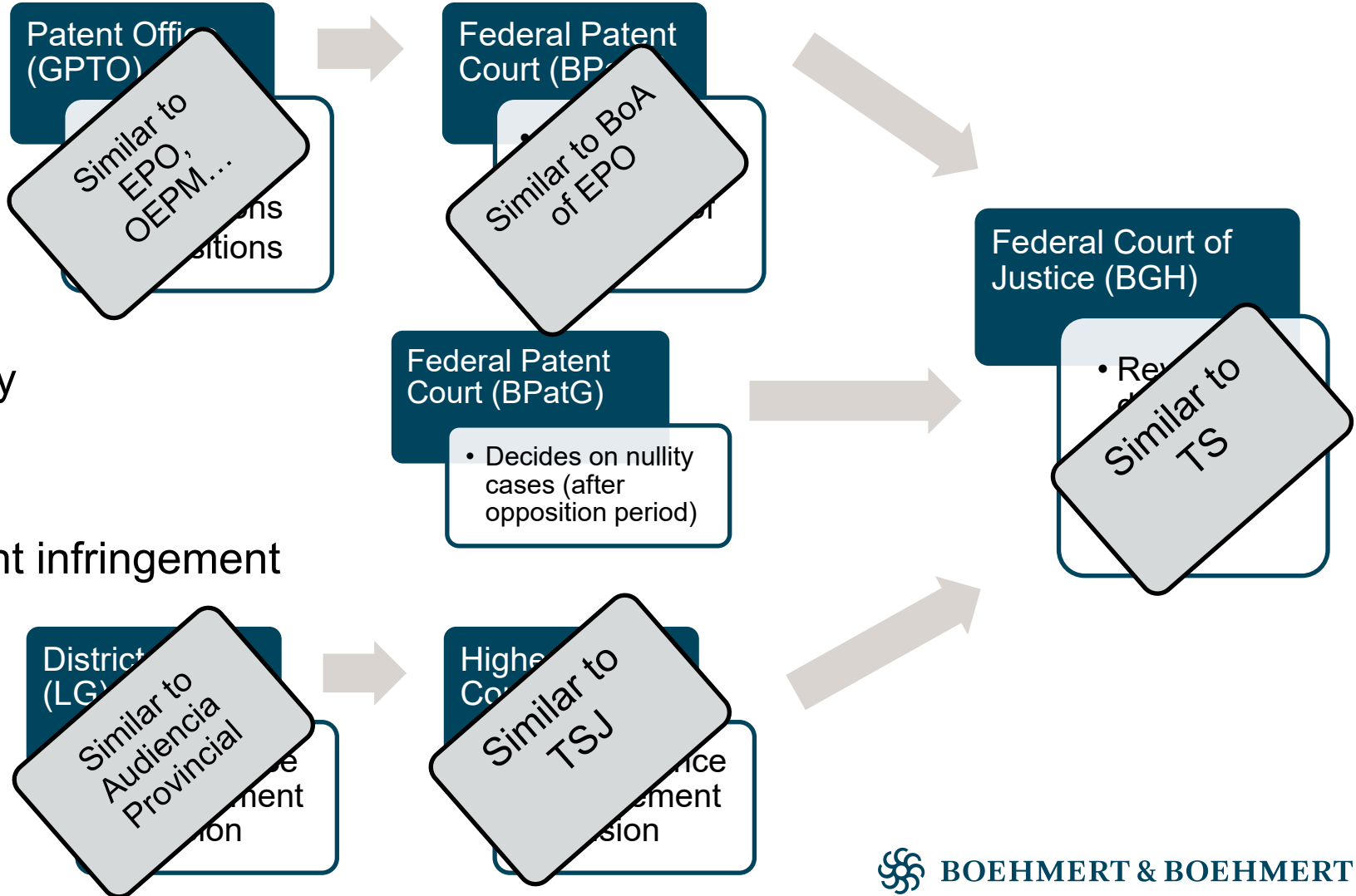

The GPTO

Largest national PTO in Europe,
5th largest in the world.

Staff > 2.800

Responsible for:

- Filing, search and examination authority for German patent applications
- Opposition proceedings against German patents
- German utility model filings and cancellation proceedings



GPTO headquarters in Munich



Deutsches
Patent- und Markenamt

Typical patent application proceedings

- Search/examination results about 8 months from filing – if requested within 4 month of priority date
- 1-3 office actions in written procedure before decision
- Informal telephone consultations with examiner possible.
- If necessary, oral proceedings take place.
- No 71(3) Communication, direct decision to grant.
- Overall duration typically around same length, but more flexible than EPO.



GPTO headquarters in Munich



Deutsches
Patent- und Markenamt

Bundespatentgericht (BPatG)

6 nullity senates,
10 patent appeal senates,
1 utility model appeal senate

Overall 99 judges, of which
42 with law background and
57 with technical background.

Responsible for:

- Appeals against decisions of GPTO (examination and opposition)
- Patent nullity cases

BPatG tends to be rather slow (usually
> **2 years** for nullity proceedings, even
longer for appeals)



BPatG in Munich



Infringement courts (1st instance)

12 first instance courts
(Landgericht, LG) across Germany,
most important venues:
Düsseldorf (3 chambers), Mannheim (2),
Munich (3), with 3 judges each

Tendency to broad claim interpretation in
Düsseldorf, Mannheim and Munich
(patentee-friendly).

Rapid written proceedings, with 2 briefs per party. Then oral hearing.

Overall, quite fast. Decisions \leq 12 months.

Rule **only** on infringement:

- Nullity is no valid defense argument.
- BUT: It is possible to request stay of infringement proceedings if nullity action is pending (courts do not like to stay, though).



Infringement courts (2nd instance)

Appeals against decision of LG possible before Higher District Courts (Oberlandesgericht, OLG), e.g.:

- Düsseldorf (2 senates),
- Karlsruhe (1),
- Munich (1).

2nd instance for factual issues.

Some differences between different district courts/ higher district courts: forum shopping!

- Munich, Düsseldorf and Mannheim (LG and OLG) generally all rather patentee-friendly
- Have all become more restrictive recently on preliminary injunctions (PI)
- PI still easier in Hamburg



See CJEU ruling on PI (case Case C-44/21 of April 28, 2022)

Düsseldorf vs Munich

Federal Court of Justice (BGH: Bundesgerichtshof)

Appeals against decision of OLG and of
Bundespatentgericht

Generally no new facts possible, mostly
judicial review!

One patent senate. Rich case law on
substantial and procedural matters:

- Added subject-matter
- Novelty and inventive step
- Sufficiency of disclosure
- Claim interpretation
- Equivalent infringement
- Contributory infringement
- Procedural aspects



German bifurcation system

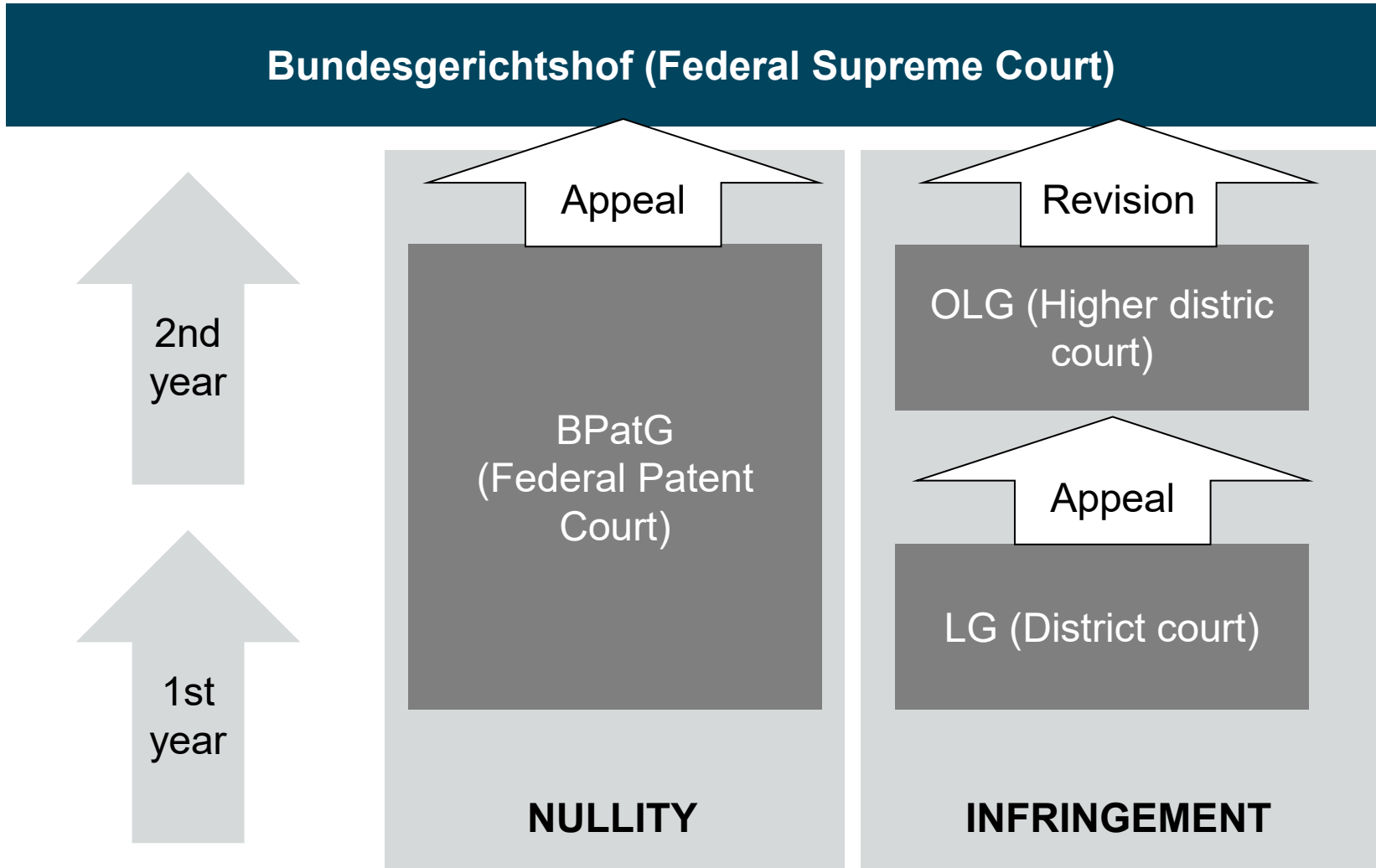

Typical costs DE

Infringement action (Value = 1 M€)		
	1st instance (LG)	2nd instance (OLG)
Court fees	18.000 €	23.500 €
Recoverable attorney fees	13.000 €	15.000 €
Recoverable patent attorney fees	13.000 €	15.000 €
Total cost risk	70.000 €	83.500 €

Nullity action (Value = 1,25 M€)		
	1st instance (BPatG)	2nd instance (BGH)
Court fees	31.000 €	42.000 €
Recov. attorney fees	15.000 €	18.000 €
Rec. patent attorney fees	15.000 €	18.000 €
Total cost risk	91.000 €	114.000 €

Typical costs UPC

Infringement action R. 15 RoP (Value = 1 M€)		
	1st instance	2nd instance
Court fees	15.000 €	15.000 €
Recoverable attorney fees	up to 200.000 €	up to 200.000 €
Total	up to 215.000 €	up to 215.000 €

Nullity counteraction R. 53 RoP (Value = up to 1,5 M€)		
	1st instance	2nd instance
Court fees	15.000 €	15.000 €
Recov. attorney fees	up to 200.000 €	up to 200.000 €
Total	up to 215.000 €	up to 215.000 €

**2) Differences:
EPO granting process vs
GPTO granting process**

Timing of proceedings

EPO

SEARCH	EXAMINATION	GRANT
≤ 6 months	1-2 years	6 months

- Search **must** be requested upon filing.
- Examination **must** be requested no later than 6 mo. after ESR

GPTO

SEARCH	EXAMINATION	GRANT
≤ 8 months	1-3 years	2 months

- Search or search + examination **may** be requested upon filing.
- Examination must be requested within **7 years** from filing. Until then, application may rest.

Official fees

	EPO	GPTO
Filing	130 €	40 €
Search	1.390 €	350 €
Examination	(+ Designation) 2.380 €	
Claims	(from 15th claim) 250 €	(from 10th claim) 20 €
Grant	990 €	0 €
Validation	???	0 €
Annuities (3-5 years)	505+630+880 = 2.015 €	70+70+100 = 240 €
TOTAL (incl. 20 claims)	8.155 €	830 €
Appeal	2.785 €	200 €

- GPTO requires filing full German translation before examination (extra costs)! (typically < 4.000 €)
- Keep in mind: GPTO: pay little and keep application on hold for 7 years!

Procedural differences

EPO	GPTO
<ul style="list-style-type: none">• Time limits are harsh, limited time extensions (1 time, 2 months).• Missing time limit has immediate legal consequence.• Search and examination must be requested within 2 years from filing.• More predictive and transparent proceedings.• 71(3) Communication: Decision to grant Auxiliary Request cannot be appealed.	<ul style="list-style-type: none">• Time limits are more flexible, can be extended several times.• Missing time limit has no immediate legal consequence.• Examination can be requested 7 years after filing.• More flexible individual-based proceedings.• Decision to grant Auxiliary Request can be appealed! (Prohibition of reformatio in peius applies)

Prior rights (Art. 54(3) EPC)

EPO	GPTO/FPC
<ul style="list-style-type: none">• Potentially colliding prior rights: (relevant for novelty only) are:<ul style="list-style-type: none">○ EP-applications,○ Euro-PCT applications	<ul style="list-style-type: none">• Potentially colliding prior rights: (relevant for novelty only) are:<ul style="list-style-type: none">○ EP-applications,○ Euro-PCT applications○ PCT applications designating Germany○ German patent applications

Formal matters

EPO

Expect more formal issues!

- Unity of invention: mind a posteriori objections in search phase for non-new independent claims.
- Limited number of independent claims (R. 43(2) EPC)
- Lack of clarity is valid ground of refusal.

GPTO

Expect less formal issues!

- Unity of invention: objections are rare and often less severe.
- No R. 43(2) EPC, only unity of invention applies. Thus, non-limited number of unitary independent claims!
- Lack of clarity is generally **not** a valid ground of refusal according to recent case law of BPatG.

Better suitable for applications in US-style (20 claims, inconsistent wording,...)

Summary

- Many similarities between German and European patent applications
- German granting system generally more flexible / less predictable.
- Fees considerably lower in Germany.
- Far fewer formal issues in Germany (clarity, unity of invention, number of independent claims...)

3) Substantial differences between European patent law and German patent law

Added subject-matter: Generalisation

EPO	GPTO/BPatG
<ul style="list-style-type: none">• Generalisation only exceptionally possible.• Very harsh disclosure test.	<ul style="list-style-type: none">• Generalisation not generally forbidden. Decided on case-by-case basis.• Less harsh disclosure test, despite „direct and unambiguous disclosure“ requirement.• Easier to formulate amendments based on specific embodiments or even drawings, à la US.

► Thus, amendment not allowed by EPO may be allowed by GPTO/BPatG!

Example: Generalisations

BGH – X ZB 1/16 – Ventileinrichtung (2016)

- Prior art: selector snaps in 5 positions. Automatic return to „Stop“ necessary for some vehicles.
- Invention: provide selector that can be easily implemented with/without automatic return using electric or pneumatic trigger.
- Original: only disclosed for at least **two** positions.
- Granted claim: at least **one** (down) position.

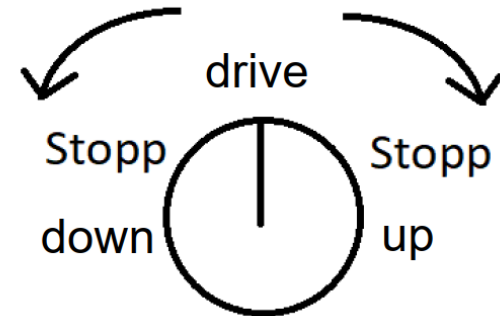

Example: Generalisations

BGH – X ZB 1/16 – Ventileinrichtung (2016)

- BPatG: added subject-matter, non-allowable generalisation.
- EPO OD: added subject-matter, non-allowable generalisation.
- BGH: skilled person realises that number of positions is not relevant for goal of the invention.
 - no added subject-matter

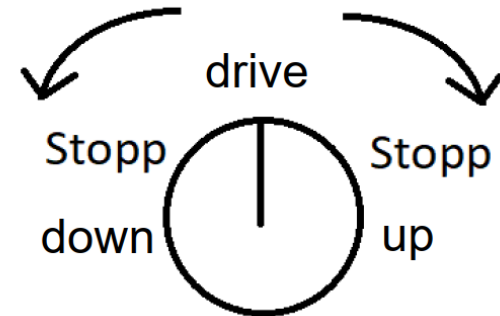

Added subject-matter: inescapable trap

EPO	GPTO/BPatG
<ul style="list-style-type: none">• Claim contains unsupported limiting feature.• Feature cannot stay in claim due to Art. 123(2) EPC• Feature cannot be removed from claim due to Art. 123(3) EPC.• Inescapable trap: Art. 123(2)/123(3) EPC → patent killed	

Added subject-matter: inescapable trap

EPO	GPTO/BPatG
<ul style="list-style-type: none">• Claim contains unsupported limiting feature.• Feature cannot stay in claim due to Art. 123(2) EPC• Feature cannot be removed from claim due to Art. 123(3) EPC.• Inescapable trap: Art. 123(2)/123(3) EPC → patent killed	<ul style="list-style-type: none">• Claim contains unsupported limiting feature. <p>BGH – Wundbehandlungsvorrichtung (2015) German footnote solution: if unsupported feature is mere limitation (no „aliud“):</p> <ul style="list-style-type: none">• Patent <u>stays valid</u>: non-supported limitation is not considered for validity but it is considered for infringement. <p>→ No inescapable trap death</p>

Foodnote solution not always applicable!

BGH – X ZR 158/18 – Zigarettenpackung (2020)

CLAIM:

Pack of smoking articles having:

- a) frame (110) for enclosing cigarettes with panel (102), side wings (104), and flaps (108, 112)*
- b) barrier sheet wrapping cigarette and frame forming sealed enclosure with sealed seams,*
- c) **all sealed seams overlie at least partly a part of the frame.***

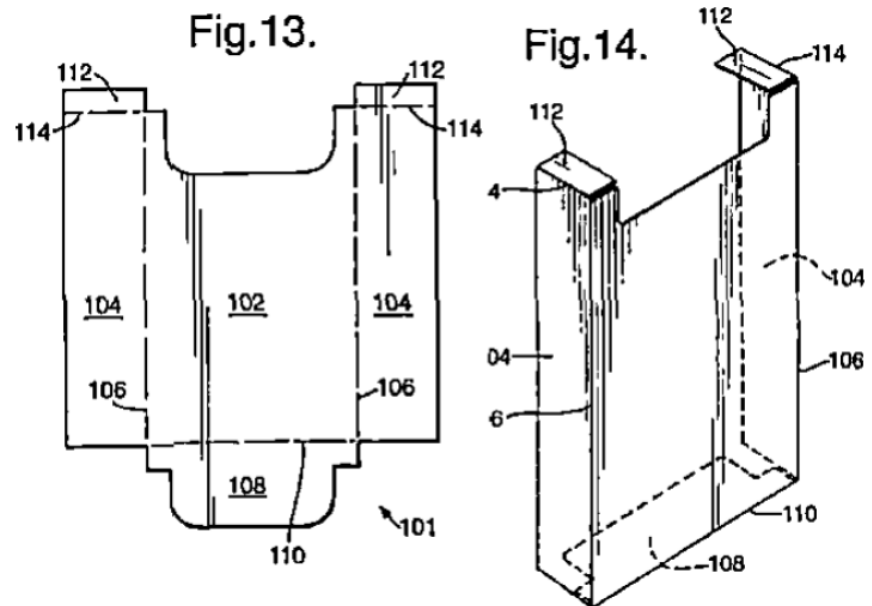

Original in description: „**lateral** sealed seams overlie **side** wings 104 to spread pressure exerted by sealer.“

Foodnote solution not always applicable!

BGH – X ZR 158/18 – Zigarettenpackung (2020)

CLAIM:

Pack of smoking articles having:

- a) *frame (110) for enclosing cigarettes with panel (102), side wings (104), and flaps (108, 112)*
- b) *barrier sheet wrapping cigarettes and frame forming sealed enclosure with sealed seams,*
- c) **all sealed seams overlie at least partly a part of the frame.**

Original in description: „**lateral** sealed seams overlie **side** wings 104 to spread pressure exerted by sealer.“

BPatG:

Feature c) not originally supported, BUT patent may continue to live under footnote rule.

Foodnote solution not always applicable!

BGH – X ZR 158/18 – Zigarettenpackung (2020)

CLAIM:

Pack of smoking articles having:

- a) *frame (110) for enclosing cigarettes with panel (102), side wings (104), and flaps (108, 112)*
- b) *barrier sheet wrapping cigarettes and frame forming sealed enclosure with sealed seams,*
- c) ***all sealed seams overlie at least partly a part of the frame.***

Original in description: „**lateral** sealed seams overlie **side** wings 104 to spread pressure exerted by sealer.“

BPatG:

Feature c) not originally supported, BUT patent may continue to live under footnote rule.

BGH:

Feature c) is not mere limitation because it defines technical effect that was not originally present: spreading pressure not just on side wings 104, but on frame in general, i.e. it is an *aliud*.

→ Patent revoked

Disclosure in drawings

EPO	GPTO/FPC
<ul style="list-style-type: none">• Same standard as for specification: directly and unambiguously (e.g. parameters not explicitly indicated are not disclosed)• It may be possible to obtain size ratios and proportions.• Beware of generalizations: drawing = specific embodiment (no cherry picking!).	<ul style="list-style-type: none">• Same (more tolerant) standard as for specification.• Case law: it is possible to obtain size ratios and proportions.

Added subject-matter in Germany

- Less harsh approach than at EPO
 - Generalisations not generally forbidden
 - Inescapable trap only for aliud, but not for mere limitation within original technical concept
- Not as easy to kill patent due to added subject-matter as at EPO.

Novelty: sub-values/sub-ranges

	Claim 1	Prior art
Amount of 2,4'-MDI [%]	10-20	0.5-25

EPO

- Sub-values are generally not disclosed, unless:
 1. Overlap is “narrow”
 2. Sub-range is far removed
 3. *Purposive selection? (no arbitrary limitation)*
- Populated case law

GPTO/FPC

- (old) case law says: sub-values and subranges are generally disclosed.
- Recent case law indefinite
- Good for making amendments, bad for novelty

Novelty: selection from lists

Claim: A3+B3

*Prior art: A=(A1, A2, A3),
 B=(B1, B2, B3)*

EPO	GPTO/FPC
<ul style="list-style-type: none">• No cherry-picking unless explicitly disclosed• Claim is novel unless prior art directly and unambiguously discloses A3+B3	<p>Case law on the issue is old:</p> <ul style="list-style-type: none">• Less strict approach, so prior art may be more problematic!• Claim may not be novel.

Inventive step

EPO	GPTO/FPC
<ul style="list-style-type: none">• “problem-solution-approach” MUST be followed• Choice of closest prior art (starting point) may be critical.• Could/would approach → skilled person needs incentives (like DE)	<ul style="list-style-type: none">• “problem-solution-approach” MAY be followed.• No limitation to 1 closest prior art• Could/would approach → skilled person needs incentives (like EP)

Claim interpretation

EPO (Opposition) = UPC?	GPTO/FPC
<p>Neutral approach</p> <ul style="list-style-type: none">• Art. 69 EPC in general not applicable (T1127/16, T2040/18, T1473/19)• Relies more on claim wording.• Neutral	<p>Patentee-friendly approach</p> <ul style="list-style-type: none">• Art. 69 EPC applicable• Tends to interpret claims functionally rather than wordly• Patentee-friendly post-grant reparations possible• Also relies on prior art cited in description!

Claim interpretation: prior art cited in description

BGH (2018) Scheinwerferbelüftungssystem

- *If prior art document is cited in patent specification as background art, claim (features in characterising part) is to be interpreted, in case of doubt, such that said prior art document is not novelty destroying.*

OLG Düsseldorf (2021) Insulinpumpe

- *Embodiments that fall under claim for a claim interpretation according to which prior art document cited in patent specification would be novelty destroying do not infringe.*

Tricky DoE in Germany!

According to German case law, equivalence requires

1. Replacement feature has same technical effect.
2. Replacement was obvious for skilled person.
3. Claimed solution supports replacement feature.

Tricky DoE in Germany!

BGH (2011) Okklusionsvorrichtung

Claim

*A collapsible medical device (60) comprising braided strands... having...
... clamps (15) adapted to clamp the strands at opposed ends of the device.*

Description

[0025]: describes claimed configuration

[0026]: *Alternatively, one can solder, braze, weld or otherwise affix the ends of the desired length together*

Infringement embodiment:

strands soldered together at **one** end.



Fig. 1A

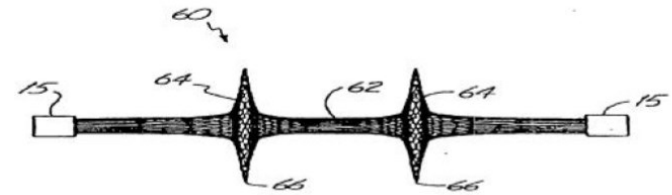

Fig. 504

Tricky DoE in Germany!

BGH (2011) Okklusionsvorrichtung

Claim

*A collapsible medical device (60) comprising braided strands... having...
... clamps (15) adapted to clamp the strands at opposed ends of the device.*

Description

[0025]: describes claimed configuration

[0026]: *Alternatively, one can solder, braze, weld or otherwise affix the ends of the desired length together*

Infringement embodiment:

strands soldered together at **one** end.



Fig. 1A

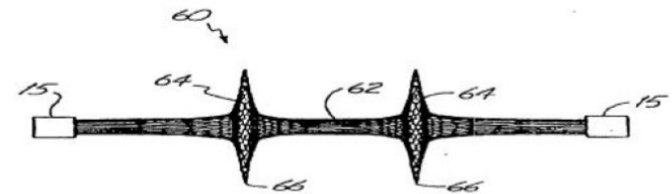

Fig. 50A

BGH:

deliberate selection!

→ Embodiments mentioned in description but not claimed are not equivalent.

Tricky DoE in Germany!

BGH (2016) V-förmige Führungsanordnung

Claim

Tool device with V-shaped guide.

Description

[0019]: guide can be V-shaped, but other shapes may also be used.

Infringement embodiment:

Tool device with U-shaped guide.

BGH?

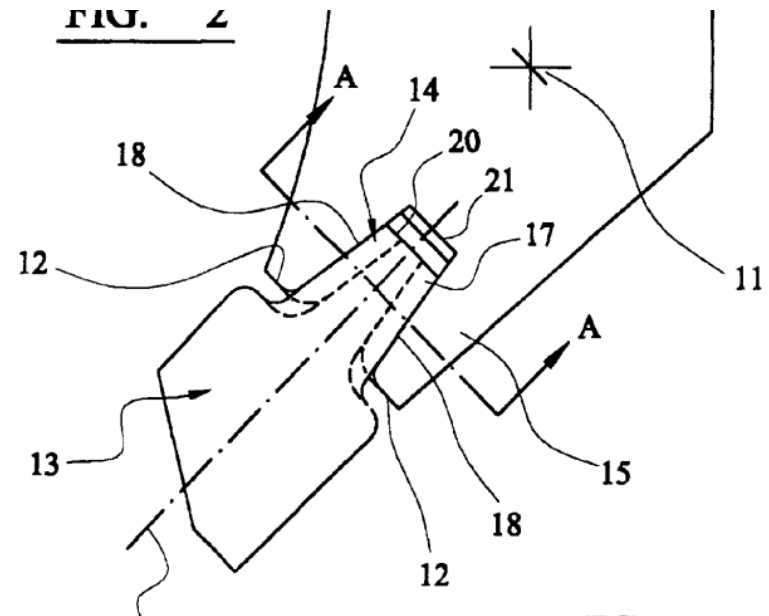

Tricky DoE in Germany!

BGH (2016) V-förmige Führungsanordnung

Claim

Tool device with V-shaped guide.

Description

[0019]: guide can be V-shaped, but other shapes may also be used.

Infringement embodiment:

Tool device with U-shaped guide.

BGH: Patent infringed, because U-shaped was not explicitly mentioned and hence not excluded.

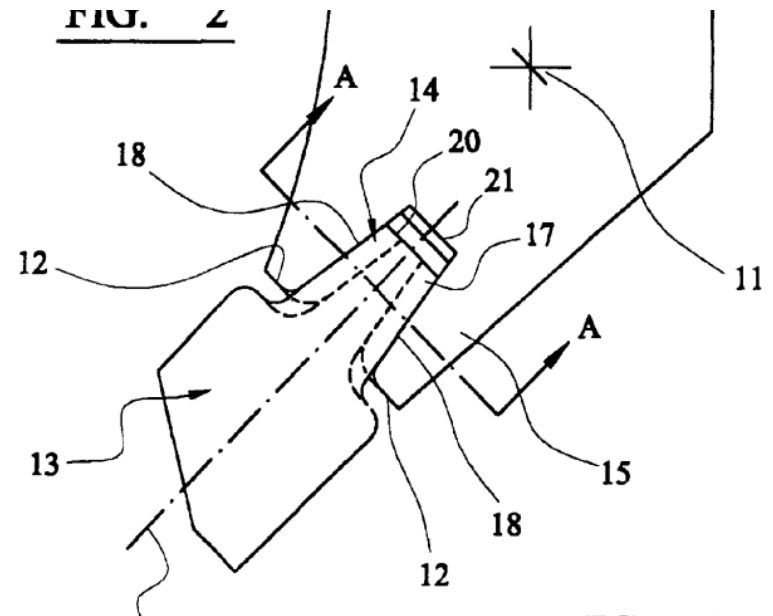

Tricky DoE in Germany!

BGH (2016) V-förmige Führungsanordnung

Similar for chemical composition in: BGH (2016) Peremetrexed

Mention in description of general teachings is not enough for excluding from equivalent scope everything different by denying question 3.

Result:

Okklusionsvorrichtung limited in practice by *V-förmige Führungsanordnung* and *Peremetrexed* to cases in which several options are explicitly mentioned in description but not claimed.

Take away message

Beware of consequences of description amendments for scope of protection in Germany

(in particular when responding to R. 71(3) EPC Communication)

- Citation of prior art in description relevant
- Mind use of *„according to an example not corresponding to the claimed invention...“*, better cancelling?

4) German utility models

Comparison German Utility Model versus German Patent:

- + Utility Model is simply obtained by registration (~ 2 months from filing application), no examination and no pre-grant opposition
- + Utility Model has lower official and renewal fees, significantly less overall costs
- + no „absolute novelty“ requirement
- + available for devices, chemical compositions, food products, pharmaceutical products and also for computer programs.
- + cancellation can be requested at GPTO

Comparison German Utility Model versus German Patent:

- (-) German Utility Model lasts up to 10 years only
- (-) no Utility Model protection for methods or biotechnological inventions
- (-) Utility model not suitable for reserving a priority date („immediate“ publication)
- (-) no assumption of validity in infringement proceedings
- (-) limited opportunities for amendments (no limitation proceedings)

Novelty requirement for utility models:

Absolute novelty for patents:

German Patent Law section 3(1): “*The state of the art comprises all knowledge made available to the public by means of **written or oral description, by use or in any other way**, before the date relevant for the priority of the application.*”

For a German utility model, prior art definition is more relaxed in that:

1. Oral description is not prejudicial.
2. Prior public use prejudicial only if in Germany.
3. Publication or prior use by applicant or predecessor in title not prejudicial if within 6 months of priority date („six-months grace period“).

„Fictional State of the Art“:

For patents: Similar provision as in Art. 54(3) EPC

For utility models: utility model can be cancelled if its subject matter is **already protected** in earlier patent or UM.

(i.e. only claims relevant!, less restrictive)

Double protection by patent and UM with same effective date possible

Uses of utility models:

- UM is of little practical importance in ordinary prosecution.
- The costs are barely lower than for a DE patent application without requesting examination.
- **Exception**: UM is important when a valid patent:
 - cannot be obtained because of own publication, oral publication, prior use outside Germany or a prior right; or
 - cannot be obtained **yet**.

German Utility Model Law section 5(1): Branching Off

A UM can be „branched off“

- a DE application,
- an EP application,
- or a PCT application for which DE is designated state.

Possible up to **two months** from end of month in which

- processing of patent application or
- any **opposition** procedure

is terminated

Difference Between Branching Off and Divisional of a Patent

1. Limited prior art
2. Quick protection by registering (ca. 2 months)
3. No double-patenting limitations
4. Branching off even during opposition (and appeal):
 - proprietor can go back to the complete disclosure of the original application
 - no limitation under Art. 123(3) EPC or section 22(1) German Patent Act

§5(1) GebrMG: Branching Off

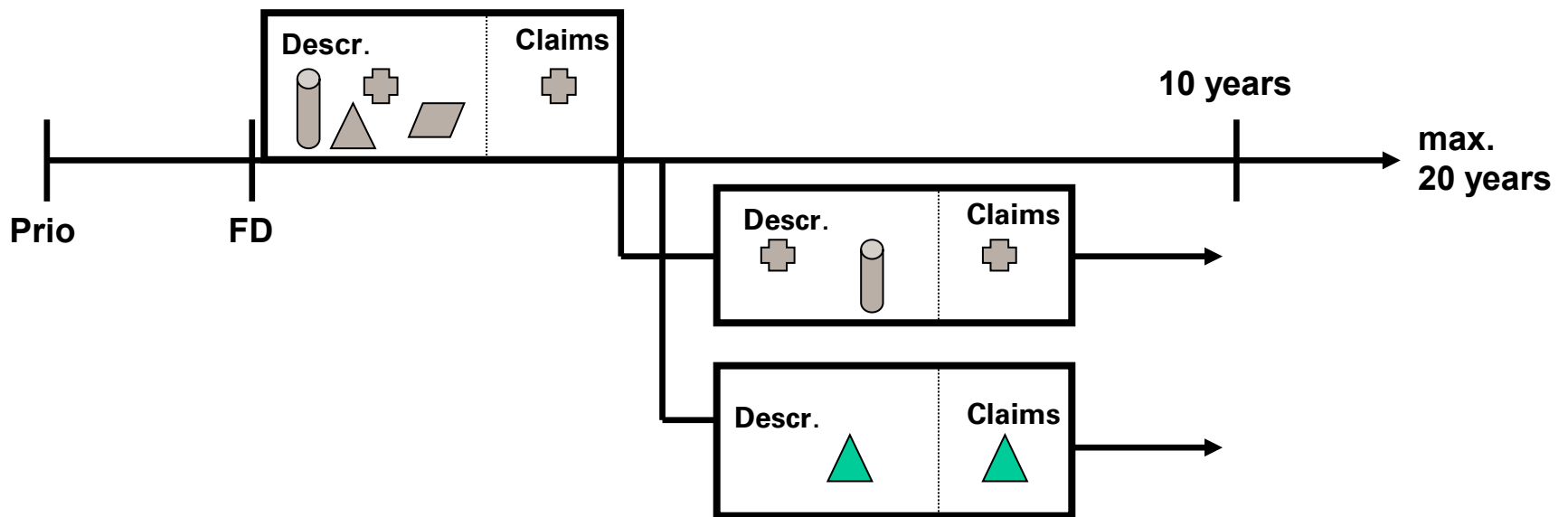

Summary

A German Utility Model can provide protection in certain cases where patent protection is

- not obtainable
- not yet obtained, or
- not available anymore.

A German Utility Model can be branched off when needed and as needed.

A German Utility Model is in fact a useful weapon in litigation (e.g. to react to opposition).

5) Strategic use of the German patent system for international clients (in particular with UPC in force)

Modifications in German patent law (IntPatÜG) due to UPC

IntPatÜG (“Gesetz über internationale
Patentübereinkommen”):

German law ruling effects in Germany of EP, PCT,...

Changes referred to UP and UPC are drafted and
will enter into force one June 1, 2023.

Modifications in German patent law (IntPatÜG) due to UPC

IntPatÜG (“Gesetz über internationale
Patentübereinkommen”):

German law ruling effects in Germany of EP, PCT,...

Changes referred to UP and UPC are drafted and
will enter into force one June 1, 2023.

Art. II, § 8: prohibition of double protection

Art. II, § 18: concurring legal actions

Modifications in German patent law due to UPC

Art. II, § 8 [*Prohibición de doble protección*]

(1) Cuando el objeto de una patente concedida mediante un procedimiento según la Ley de patentes [alemana] sea una invención para la cual se haya concedido al mismo inventor o sucesor en derecho una patente europea con efectos en Alemania con la misma prioridad, la patente deja de producir efectos en la medida en que proteja la misma invención que la patente europea, a partir del momento en que

1. finalice el plazo para presentar oposición contra la patente europea sin que se haya presentado oposición alguna,
2. finalice con decisión firme el procedimiento de oposición manteniéndose en vigor la patente, o
3. se conceda la patente, cuando ello suceda tras los instantes mencionados en los numerales 1 y 2.

(2) Las consecuencias legales de (1) son definitivas.

Modifications in German patent law due to UPC

Art. II, § 8 [*Prohibición de doble protección*] (*ver art. 160 LP*)

(1) Cuando el objeto de una patente concedida mediante un procedimiento según la Ley de patentes [alemana] sea una invención para la cual se haya concedido al mismo inventor o sucesor en derecho una patente europea con efectos en Alemania **que no esté sometida a la jurisdicción exclusiva del Tribunal Unificado de Patentes debido al uso de la excepción prevista en el Art. 83 apartado 3 del Acuerdo sobre el Tribunal Unificado de Patentes** con la misma prioridad, la patente deja de producir efectos en la medida en que proteja la misma invención que la patente europea, a partir del momento en que

1. finalice el plazo para presentar oposición contra la patente europea sin que se haya presentado oposición alguna,
2. finalice con decisión firme el procedimiento de oposición manteniéndose en vigor la patente,
3. **se haga efectivo respecto a la patente europea el uso de la excepción prevista en el Art. 83 apartado 3 del Acuerdo sobre el Tribunal Unificado de Patentes, cuando ello suceda tras los instantes mencionados en los numerales 1 y 2, o**
4. se conceda la patente, cuando ello suceda tras los instantes mencionados en los numerales 1 a **3**.

(2) Las consecuencias legales de (1) son definitivas.

Changes in double protection provisions

- Double protection prohibition for EP (opt-out) + DE (see Art. 160 LP)
But...

- No double protection prohibition for
* UP + DE or EP (no opt-out opt-in*) + DE!

Thus, UP/EP (no opt-out or opt-in*) can coexist with DE!

IDEA: Use this new legal possibility if DE is important market, at least for key patents.

**opt-in must be prior to grant of DE patent!*

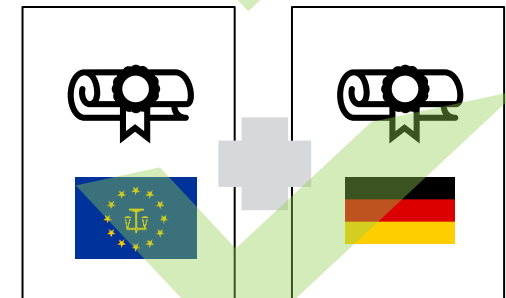
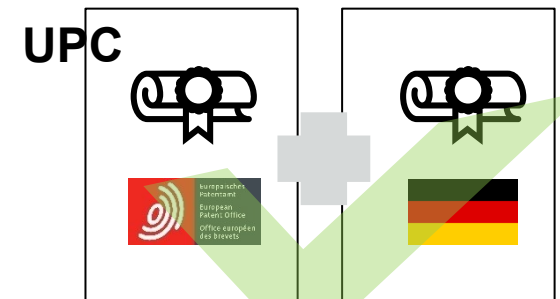
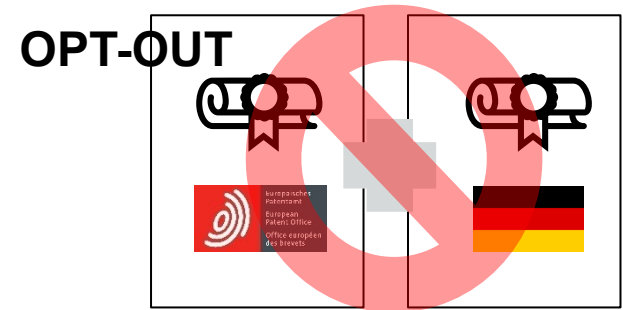

Modifications in German patent law due to UPC

Art. II, § 18 [*Prohibición de doble acción*]

(1) La acción por violación o intención de violación de una patente concedida en un procedimiento con arreglo a la Ley de Patentes [alemana] se declarará inadmisibles,

1. si el objeto de la patente es una invención para la que se haya concedido una patente europea o una patente europea con efecto unitario con la misma prioridad al mismo inventor o a su causahabiente con efectos en la República Federal de Alemania, y

2. si existe un procedimiento pendiente ante el Tribunal Unificado de Patentes contra la misma parte por infracción o intención de infracción de la patente europea o de la patente europea con efecto unitario mencionada en el numeral 1 basada en la misma forma de infracción o si el Tribunal Unificado de Patentes ha dictado sentencia firme respecto a dicho procedimiento, y

3. siempre que el demandado formule una correspondiente objeción en la primera vista en la que tenga motivo para ello, antes del inicio de la vista oral principal sobre el fondo del asunto.

(2) Si el demandado formula una objeción en virtud del apartado (1), el Tribunal podrá ordenar que se suspenda el procedimiento hasta que se haya resuelto el procedimiento ante el Tribunal Unificado de Patentes.

(3) Los apartados 1 y 2 se aplicarán mutatis mutandis a los certificados complementarios de protección.

(4) Los apartados 1 y 2 **no** se aplicarán a las medidas provisionales o cautelares.

Strategic considerations

Use national patent applications in Germany:

1. As back-up for UP / non-opted-out EP
2. For additional/reliable protection in view of relevant case law
3. For quick protection/enforcement

Strategic considerations

Use national patent applications in Germany :

1. As back-up for UP / non-opted-out EP
2. For additional/reliable protection in view of relevant case law
3. For quick protection/enforcement

German application as back-up

UP may be limited/revoked at once for all UPC-states!

Revocation/limitation may be due to substantial patent law of UPC/EPO, e.g. added subject-matter or interpretation of prior art, which may be differently assessed in Germany.

Active German patent application may allow back-up protection in Europe's biggest market.

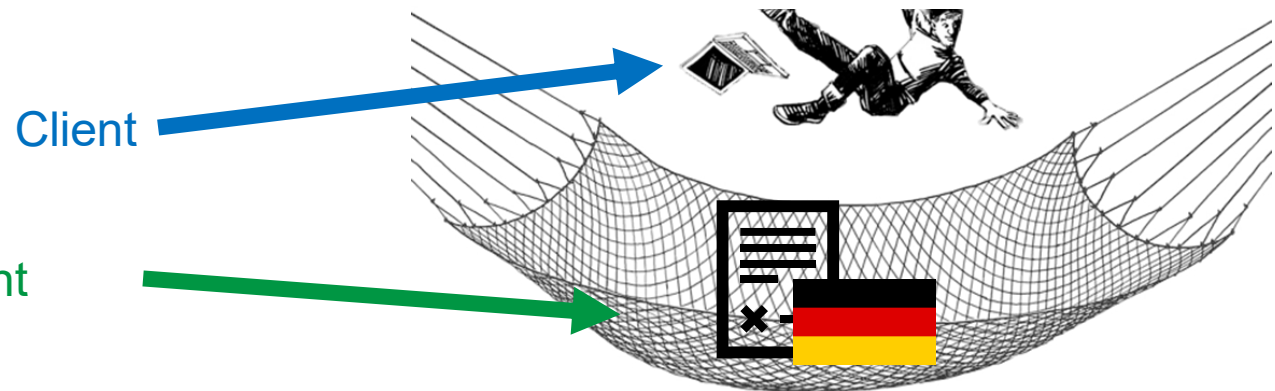
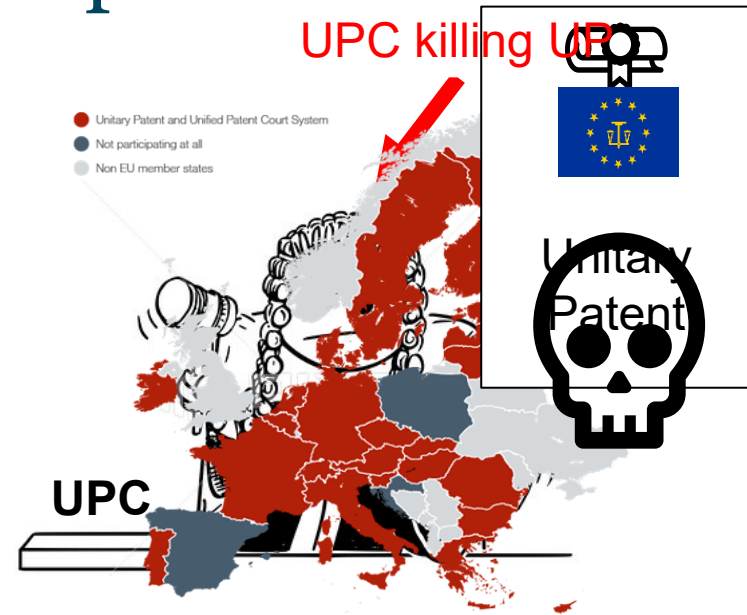

Strategic considerations

Use national patent applications in Germany:

1. As back-up for UP / non-opted-out EP
2. For additional/reliable protection in view of relevant case law
3. For quick protection/enforcement

German patents for enhanced protection

Decision criteria of UPC yet unknown. Case law will have to evolve (NL? DE? FR?). But we know case law in Germany for German patents.

More favourable claim interpretation in DE?

- German case law: description+drawings can be used to interpret claims but generally not to *limit* claims.
- Claims are interpreted such that all described embodiments are covered.
- Prior art cited in description is interpreted construed as not falling under claim.

German patents for enhanced protection

Decision criteria of UPC yet unknown. Case law will have to evolve (NL? DE? FR?). But we know case law in Germany for German patents.

More favourable claim interpretation in DE?

- Less harsh approach to added subject-matter in DE
- No inescapable trap in case of mere limitation.

German patents for enhanced protection

Decision criteria of UPC yet unknown. Case law will have to evolve (NL? DE? FR?). But we know case law in Germany for German patents.

More favourable claim interpretation in DE?

Prosecution file history (estoppel): not relevant in Germany. What about UPC?

Infringement test under DoE: clear in Germany. What about UPC?

Cross-border contributory infringement: choose wisely!

Cross-border contributory infringement

German Patent Act, Section 10(1):

*“The patent shall confer on its proprietor the right to prevent any third party not having the proprietor’s consent from **supplying or offering to supply, within Germany**, any persons other than a party entitled to exploit the patented invention, with means, relating to an essential element of that invention, **for use within Germany**, when the third party knows or it is obvious from the circumstances that those means are suitable and intended for using that invention.”*

Cross-border contributory infringement

So, in principle, contributory infringement under German law requires that **both** the **supply** of the means and the **subsequent indirect infringement** take place in Germany:

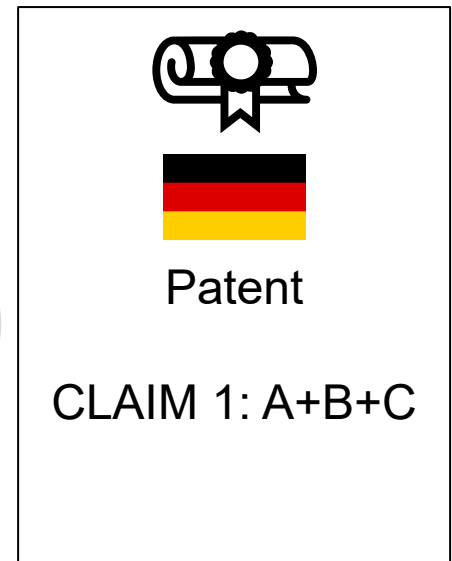
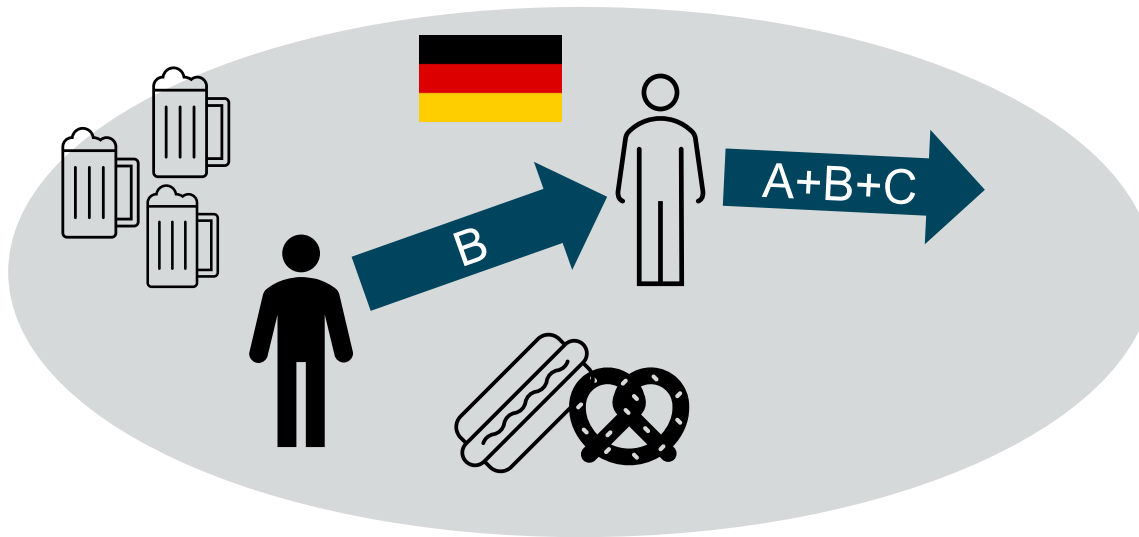



 = Indirect patent infringer in Germany

Cross-border contributory infringement

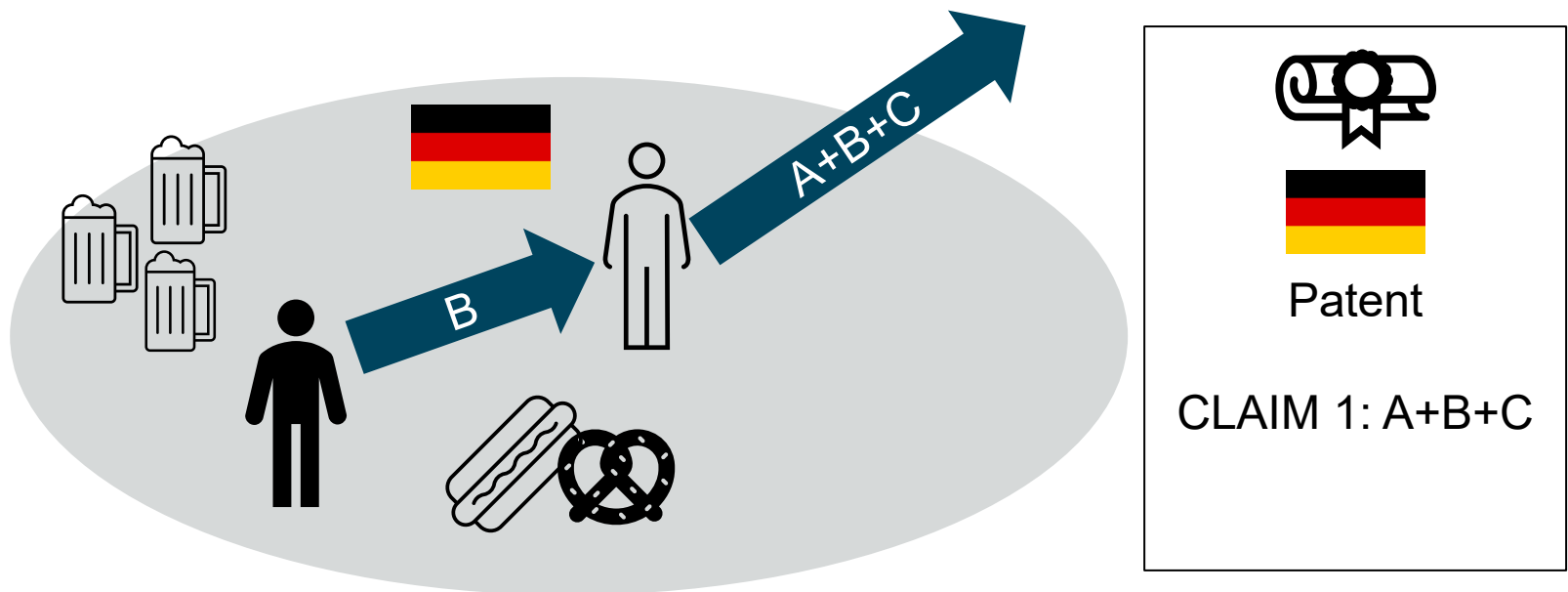
There is no contributory infringement if subsequent indirect infringement takes place outside Germany:



  Indirect patent infringer in Germany

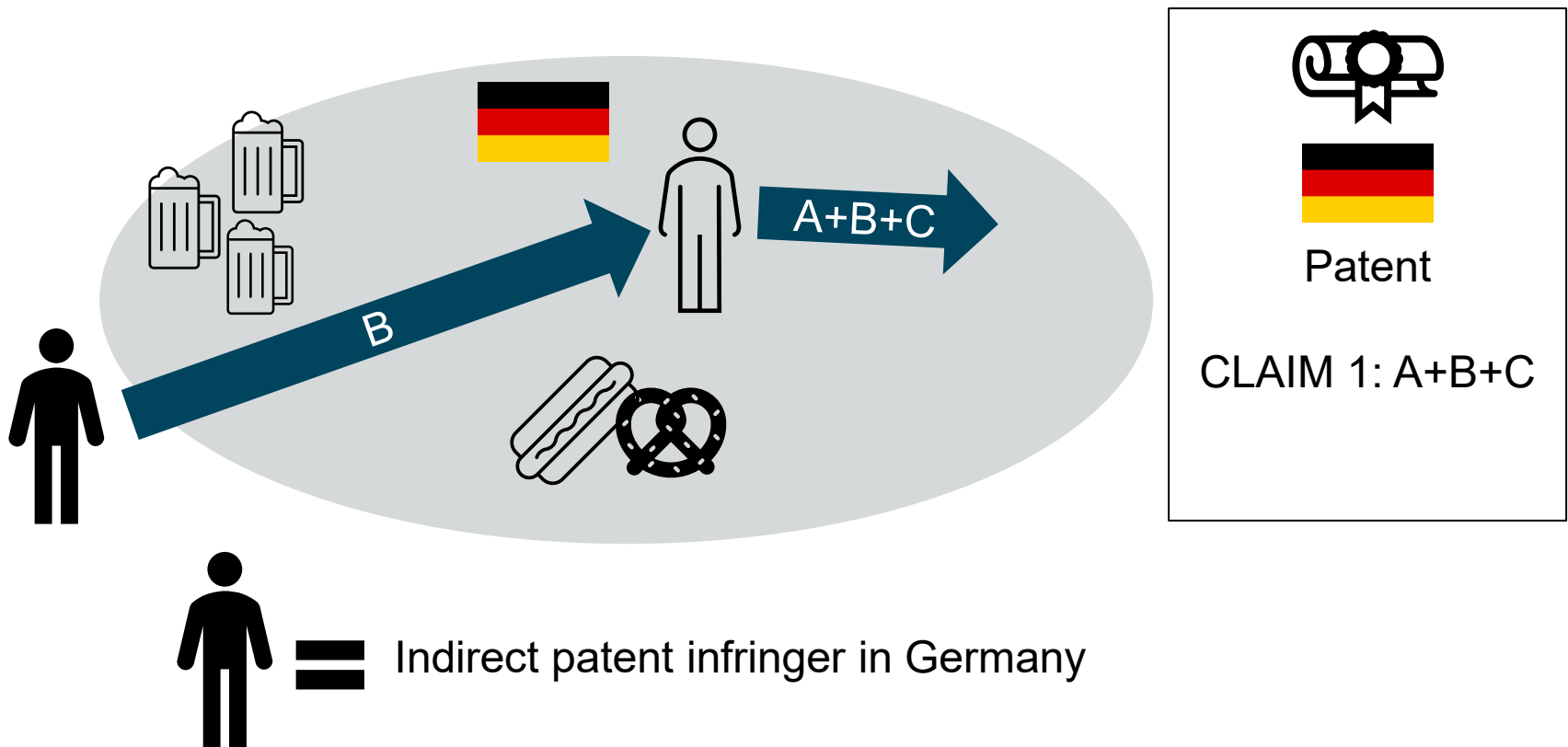

Cross-border contributory infringement

So, in principle, contributory infringement under German law requires that both the supply of the means and the subsequent indirect infringement take place in Germany:



Cross-border contributory infringement

So, in principle, contributory infringement under German law requires that both the supply of the means and the subsequent indirect infringement take place in Germany:

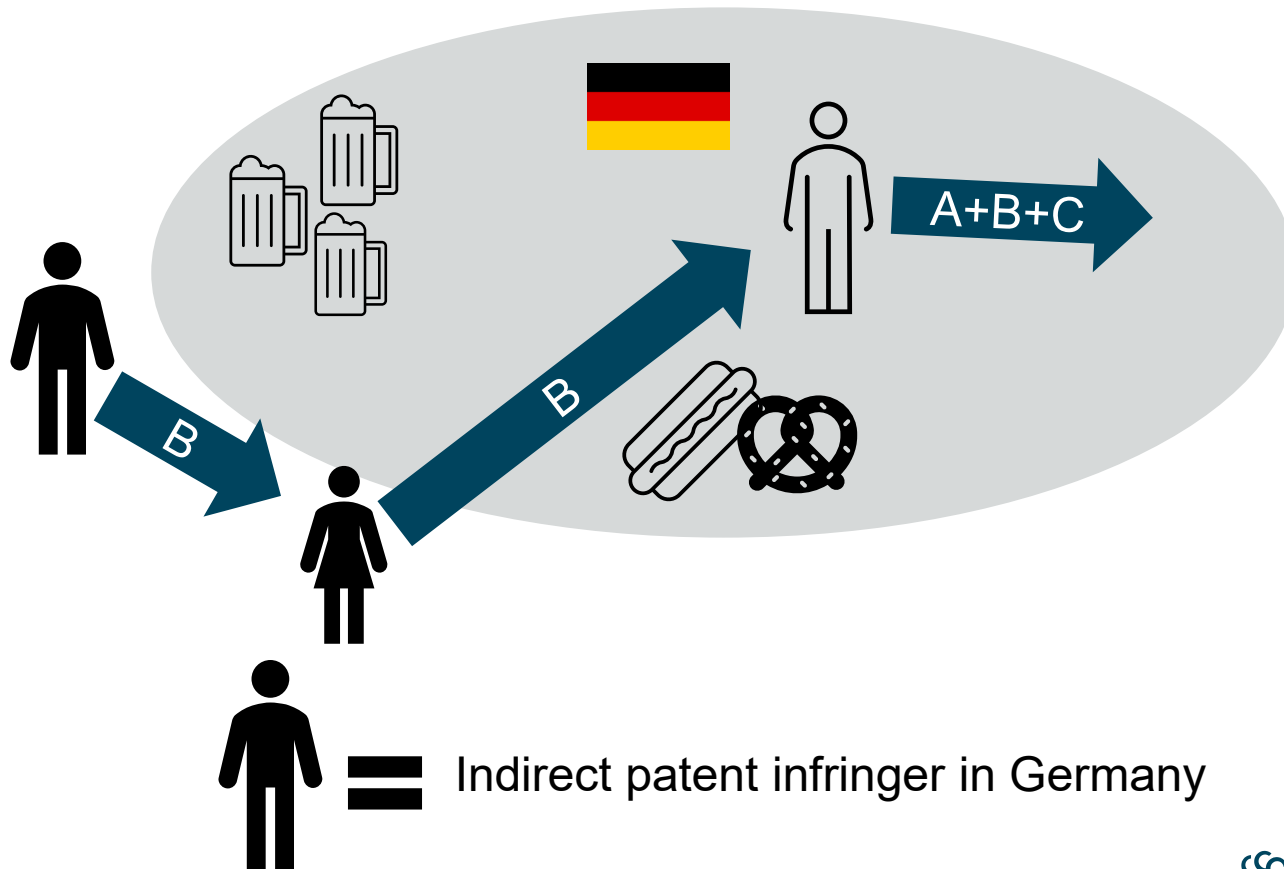

Patent

CLAIM 1: A+B+C

Cross-border contributory infringement

So, in principle, contributory infringement under German law requires that both the supply of the means and the subsequent indirect infringement take place in Germany:



 = Indirect patent infringer in Germany

Cross-border contributory infringement

There is no contributory infringement of German patent if subsequent indirect infringement takes place outside Germany:

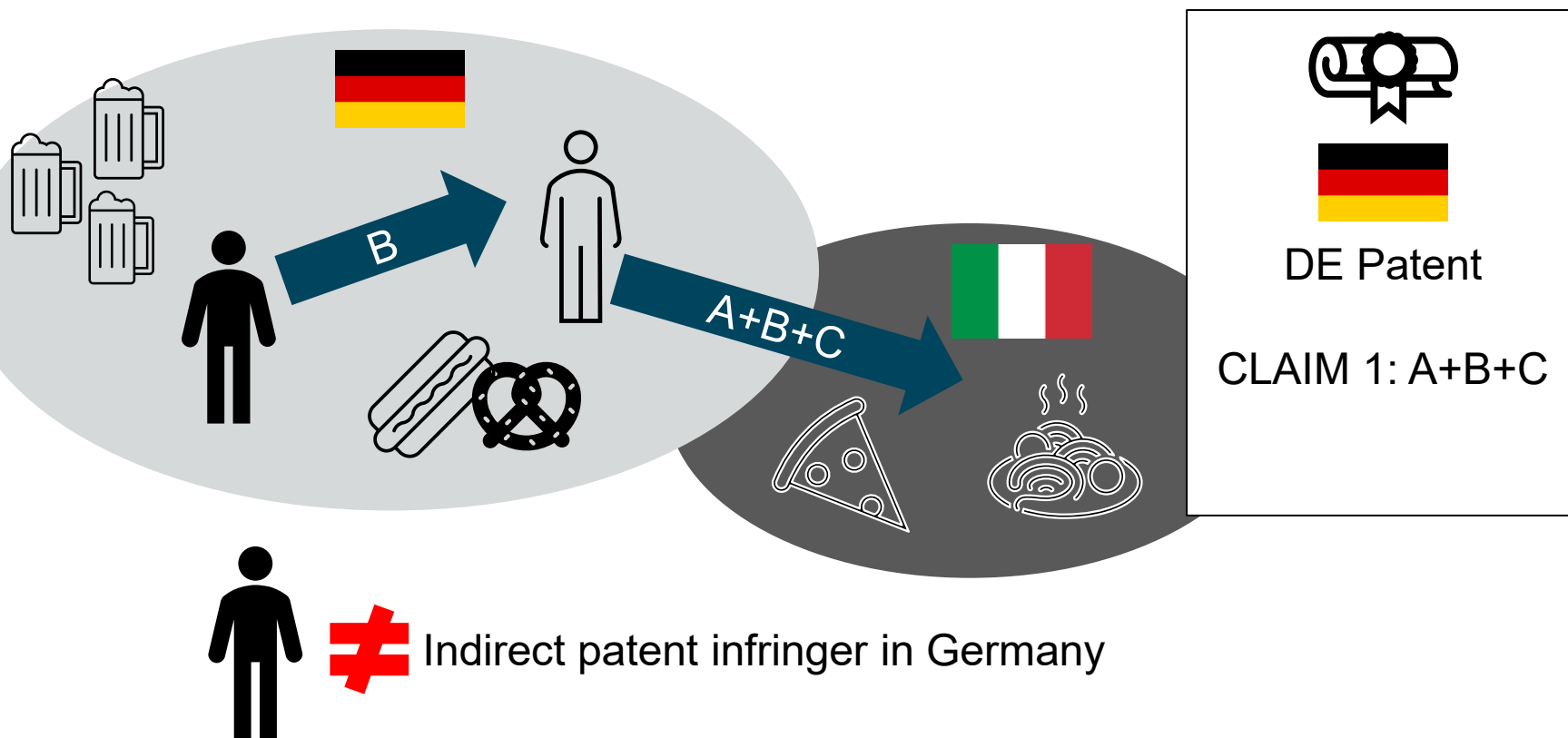

Cross-border contributory infringement

German Patent Act, Section 10(1):

*“The patent shall confer on its proprietor the right to prevent any third party not having the proprietor’s consent from **supplying or offering to supply, within Germany**, any persons other than a party entitled to exploit the patented invention, with means, relating to an essential element of that invention, **for use within Germany**, when the third party knows or it is obvious from the circumstances that those means are suitable and intended for using that invention.”*

Cross-border contributory infringement

There is no contributory infringement of German patent if subsequent indirect infringement takes place outside Germany:

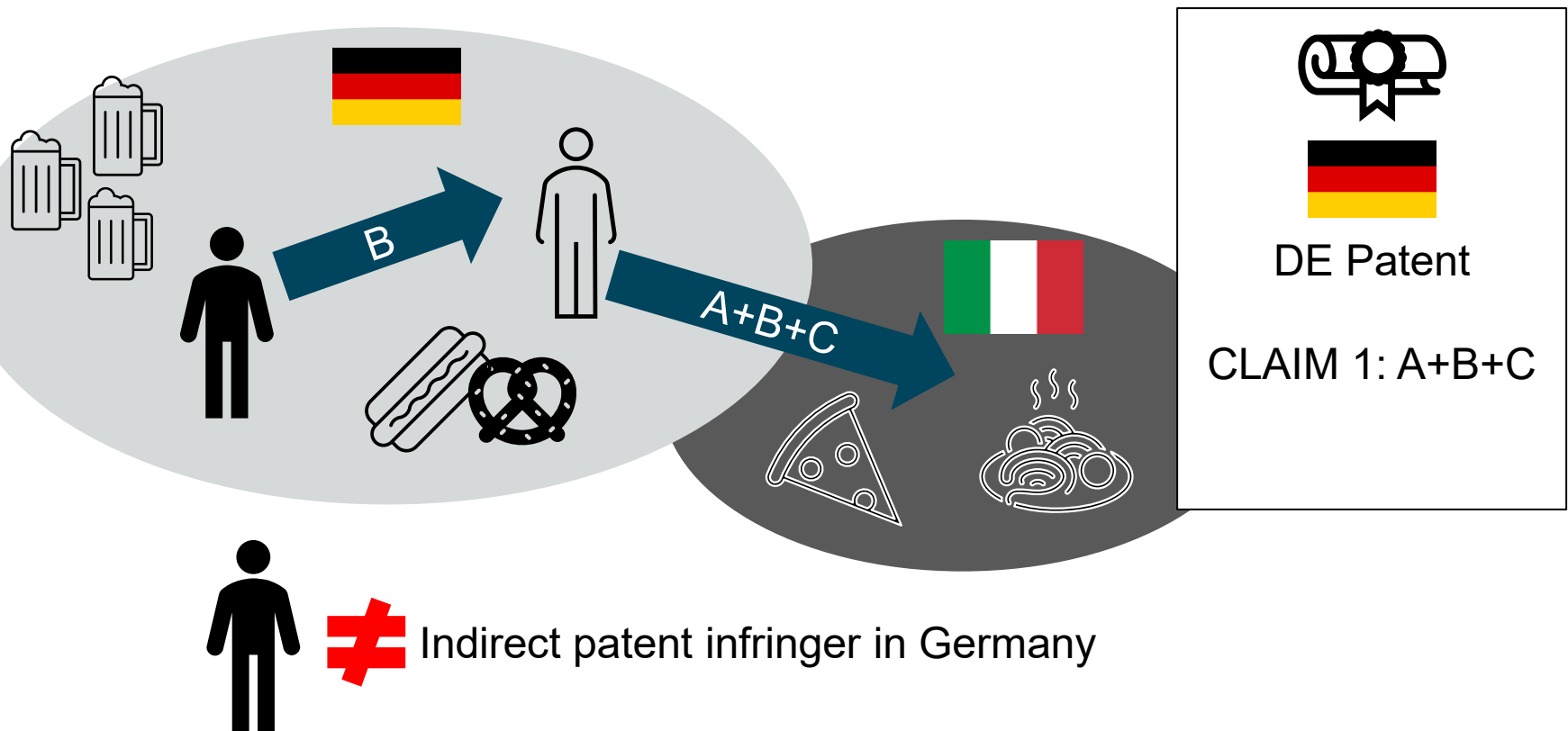

Cross-border contributory infringement

But there is contributory infringement of UP even if subsequent indirect infringement and supply take place in different UPC states.

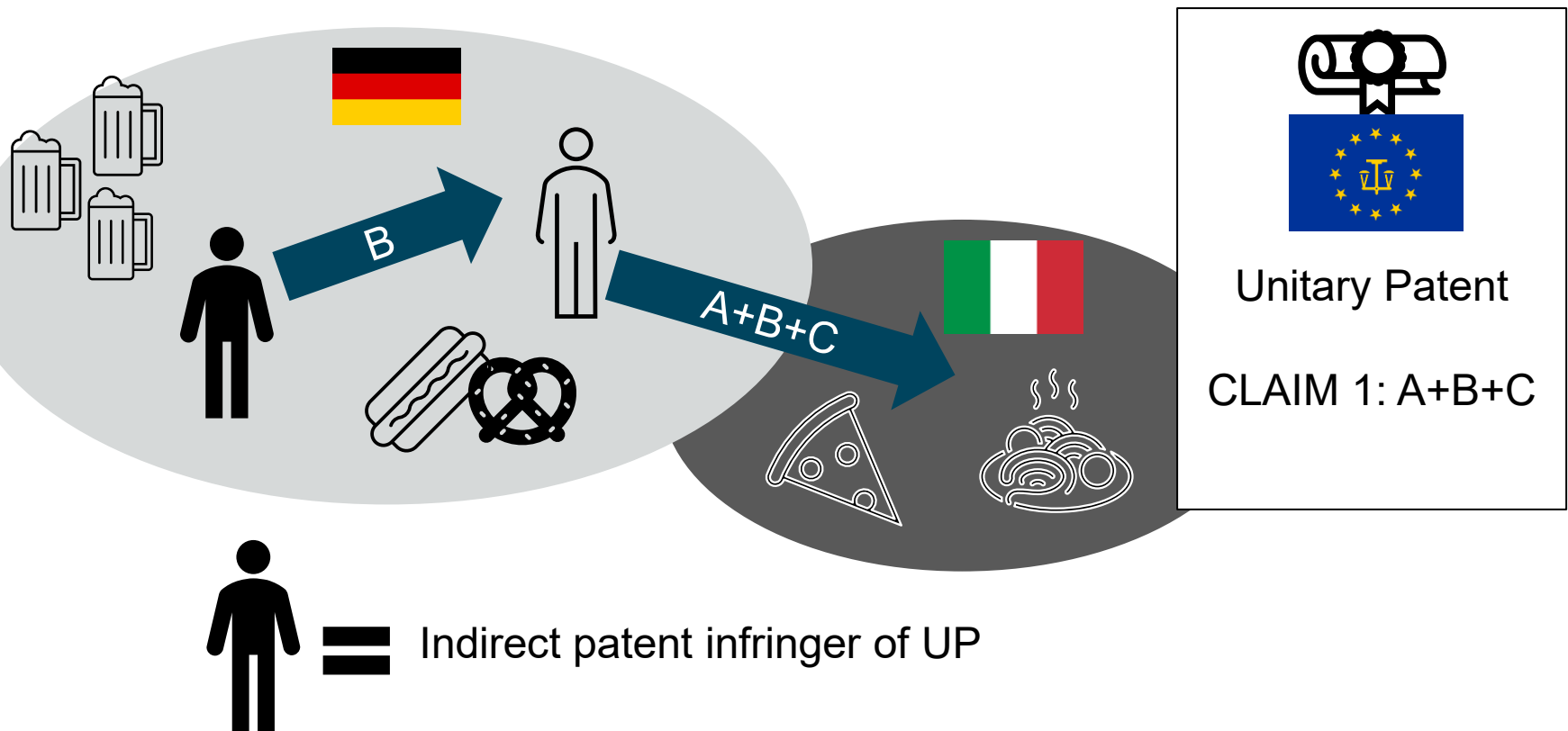

Cross-border contributory infringement

UPCA, Art. 26(1):

*“A patent shall confer on its proprietor the right to prevent any third party not having the proprietor’s consent from **supplying or offering to supply, within the territory of the Contracting Member States in which that patent has effect**, any person other than a party entitled to exploit the patented invention, with means, relating to an essential element of that invention, for putting it into effect **therein**, when the third party knows, or should have known, that those means are suitable and intended for putting that invention into effect..”*

Cross-border contributory infringement

Both supply (DE) and subsequent indirect infringement (IT) take place within UPC territory.

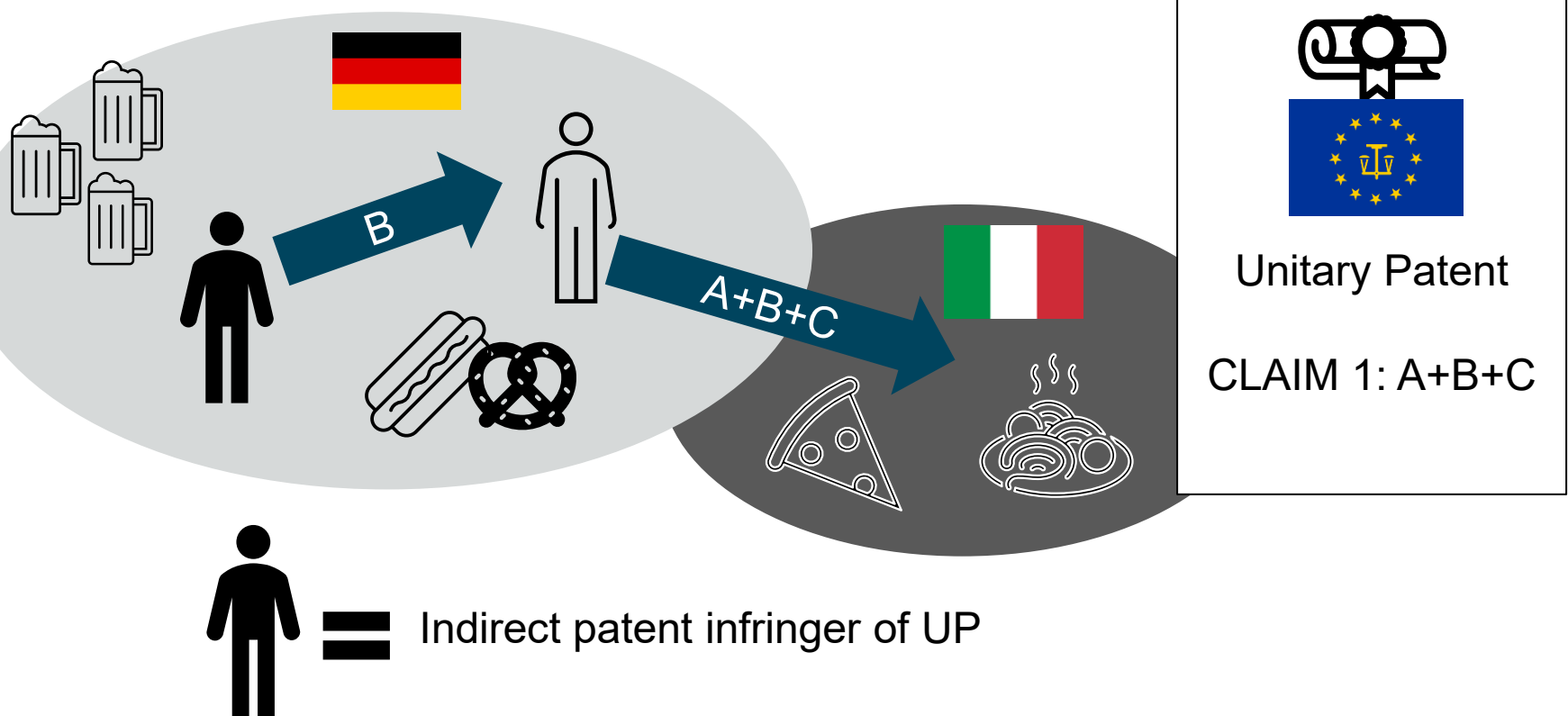

Cross-border contributory infringement

Supply (DE), manufacturing (FR) and subsequent indirect infringement (IT) take place within UPC territory.

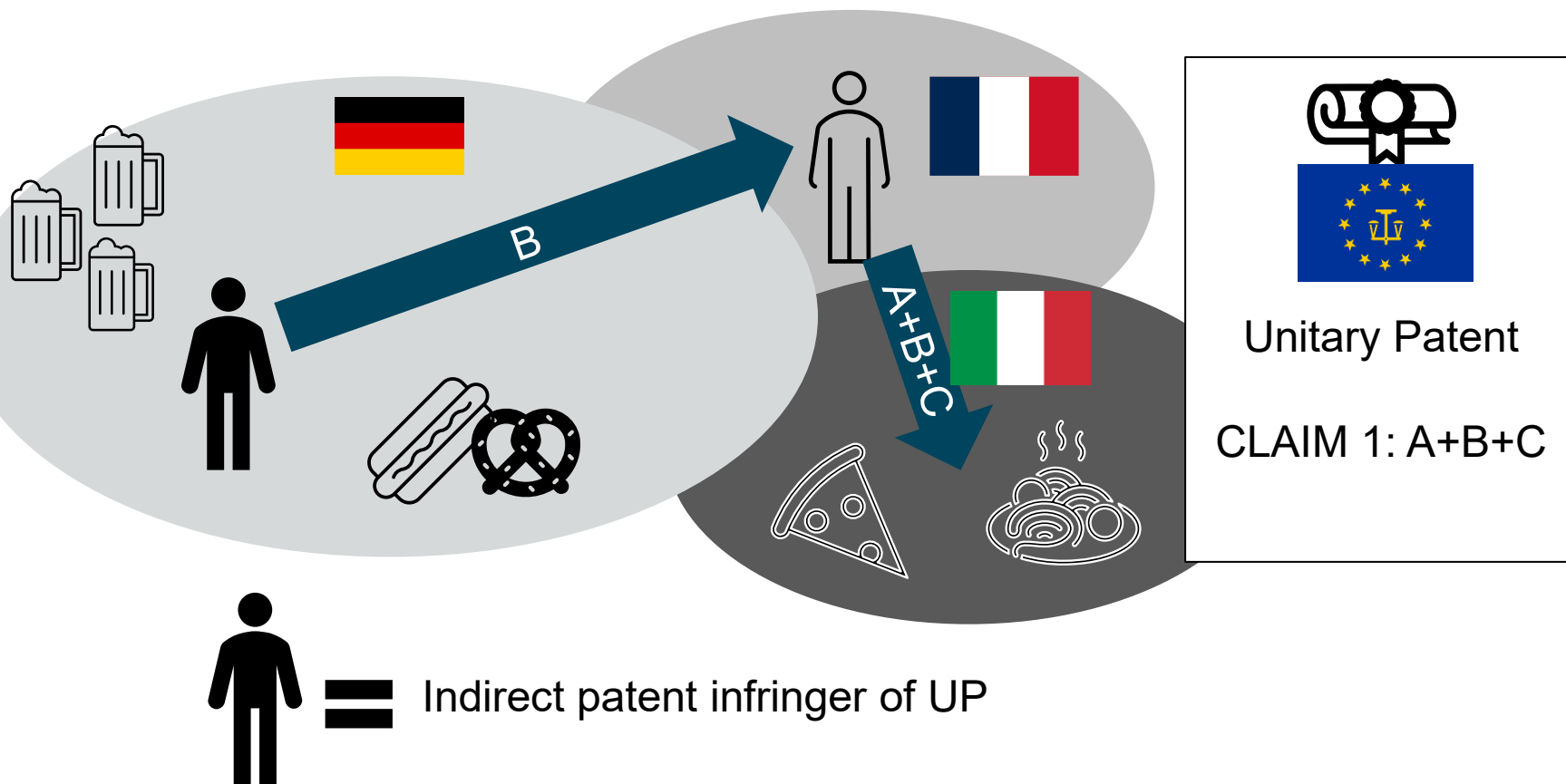

Cross-border contributory infringement

Country chain does not matter within UPC territory.

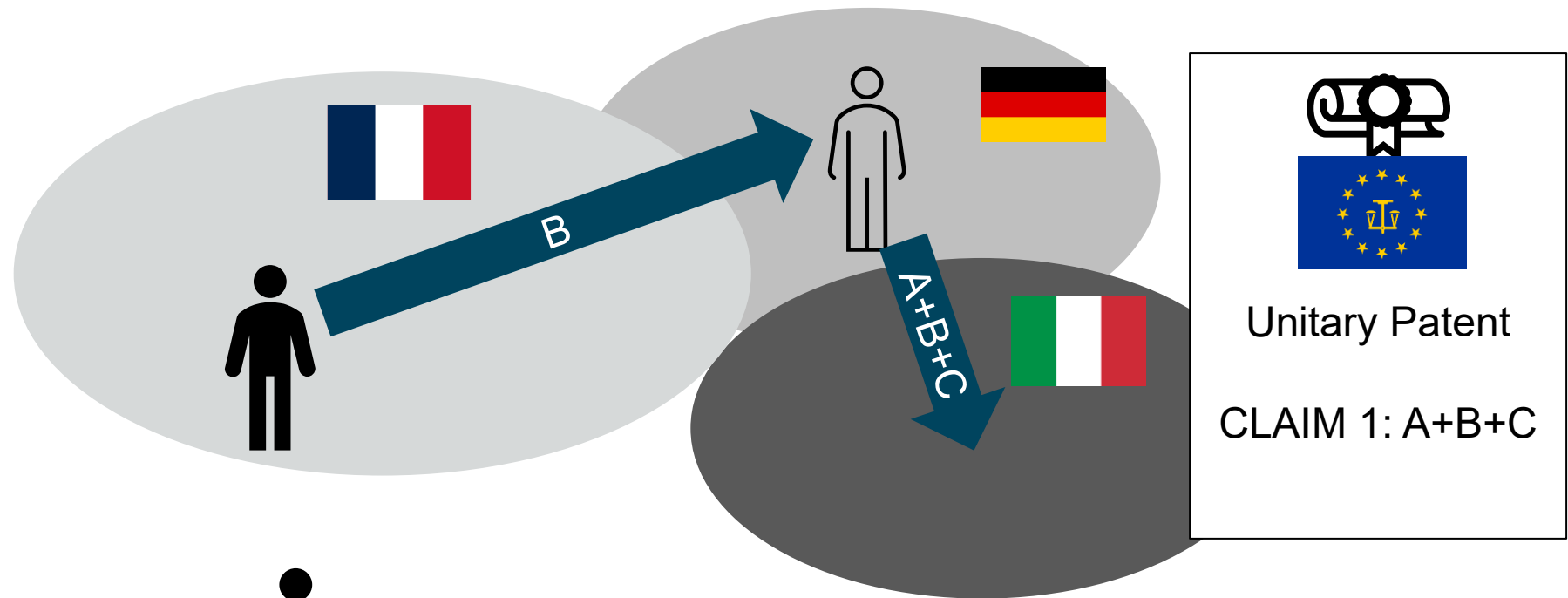

Indirect patent infringer of UP

Cross-border contributory infringement

Country chain does not matter within UPC territory.

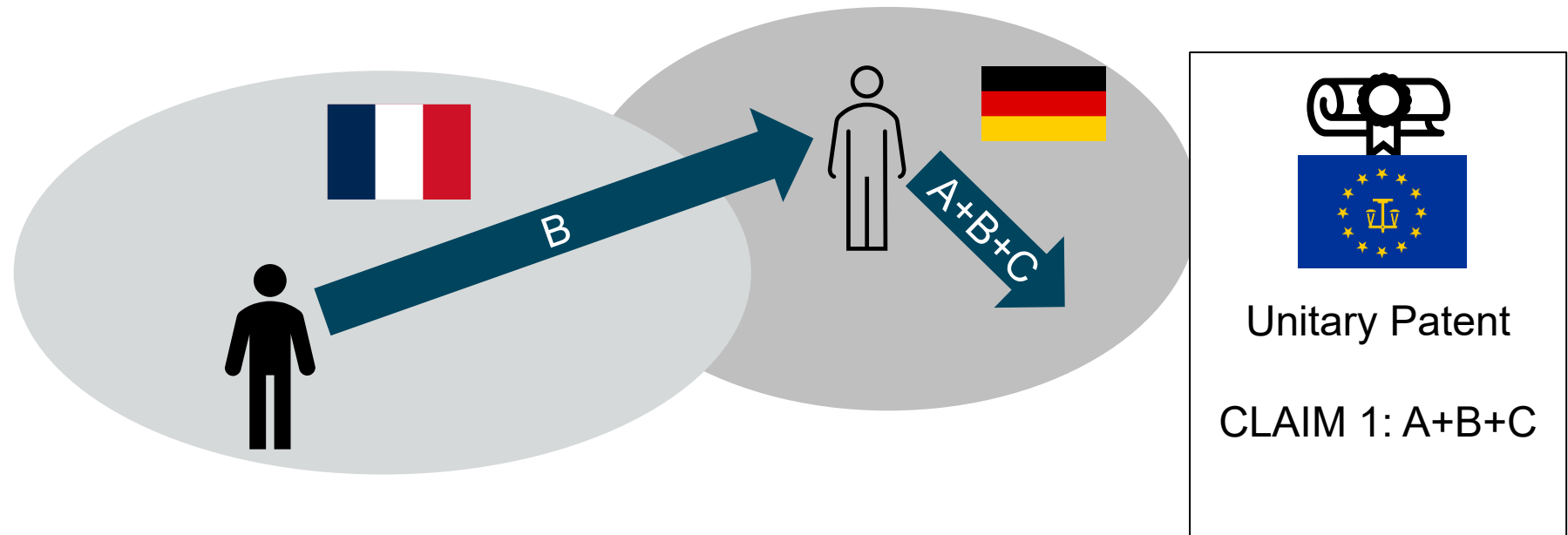

 = Indirect patent infringer of UP

Cross-border contributory infringement

But some cases are not (yet) covered by UP...

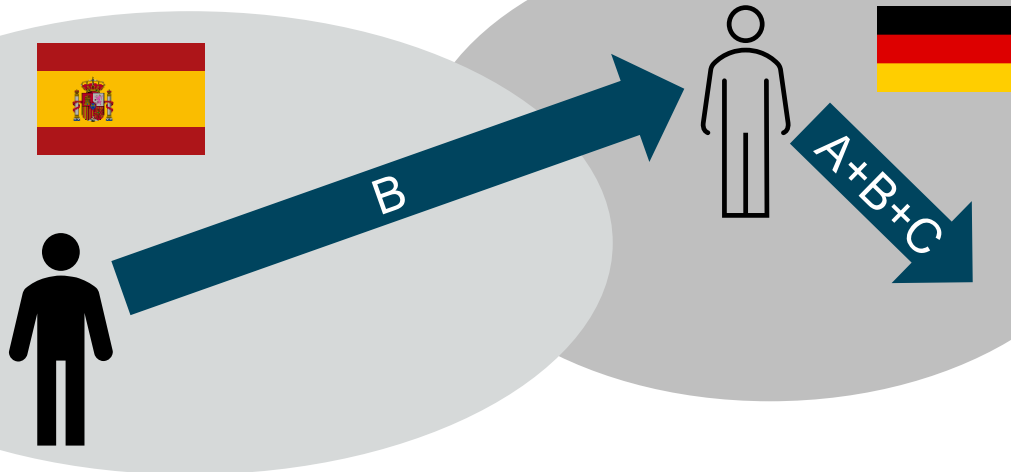

Unitary Patent
CLAIM 1: A+B+C



Indirect patent infringer of UP

Cross-border contributory infringement

...while being covered by German patent in view of existing case law.

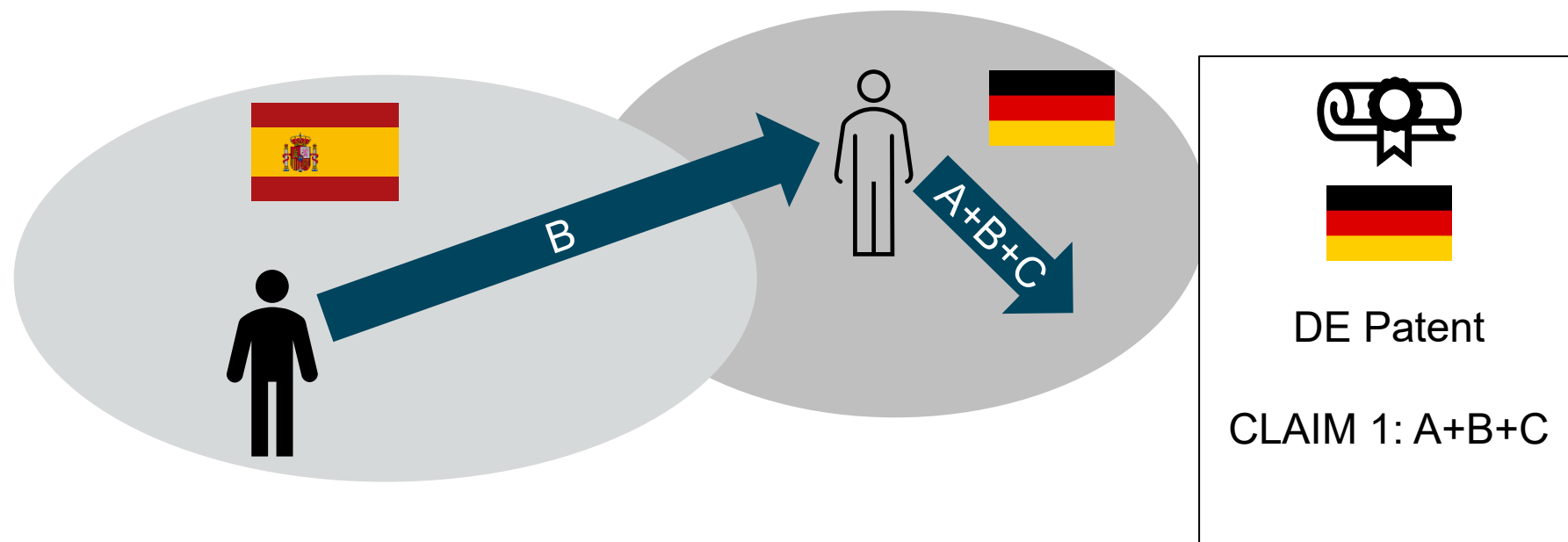

Indirect patent infringer of UP

Cross-border contributory infringement

But there is contributory infringement of UP even if subsequent indirect infringement and supply take place in different UPC states.

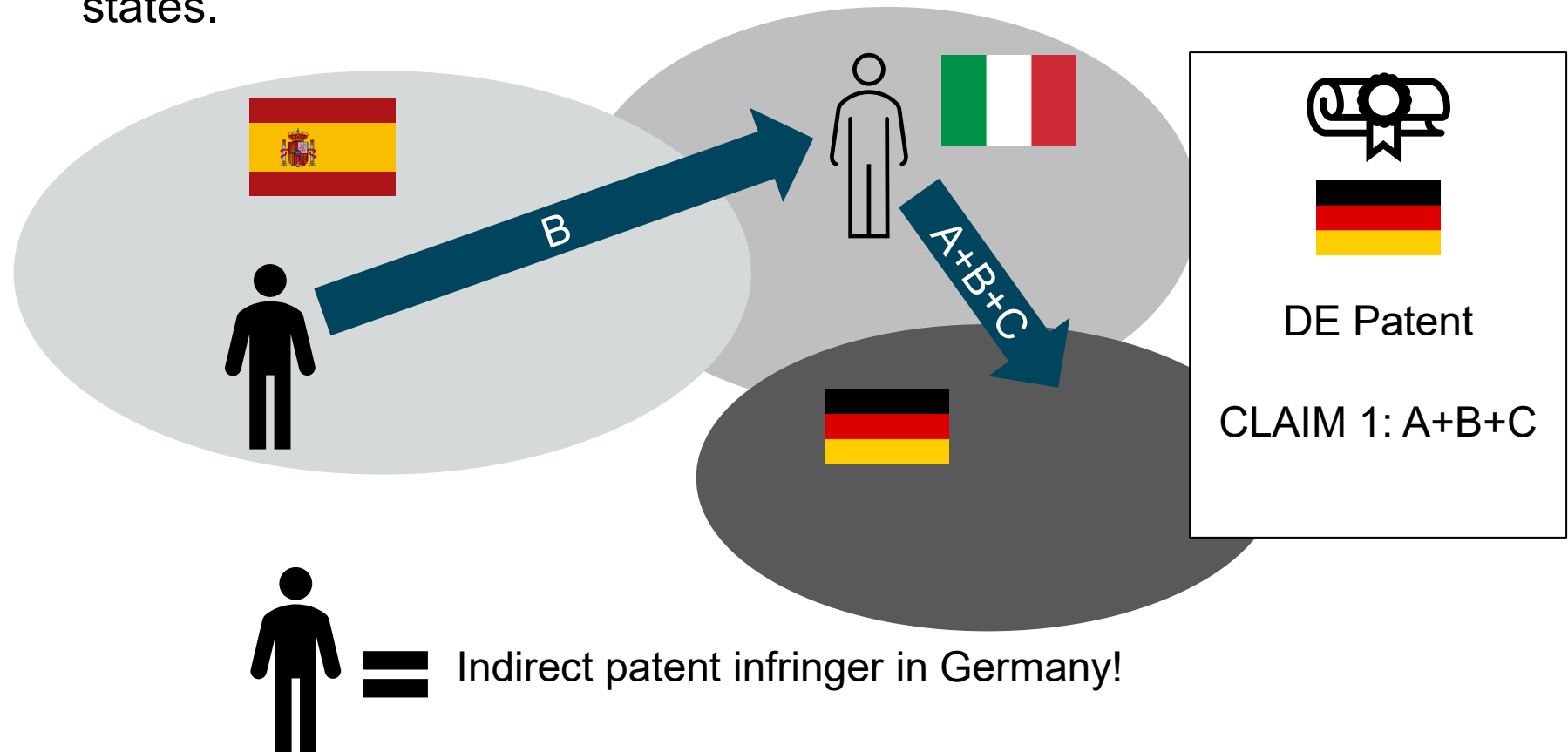

Cross-border contributory infringement

But there is contributory infringement of UP even if subsequent indirect infringement and supply take place in different UPC states.

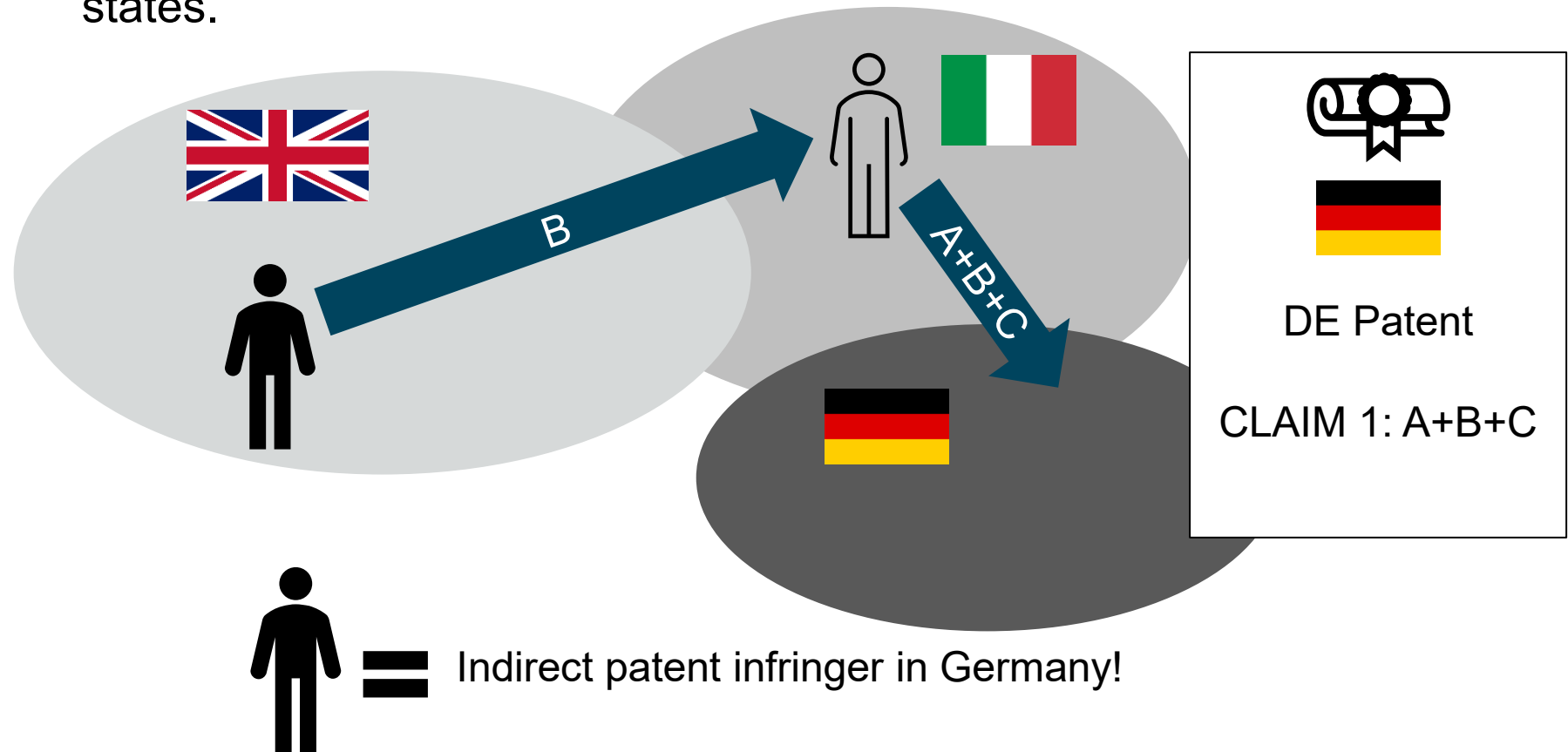

Cross-border contributory infringement

But there is contributory infringement of UP even if subsequent indirect infringement and supply take place in different UPC states.

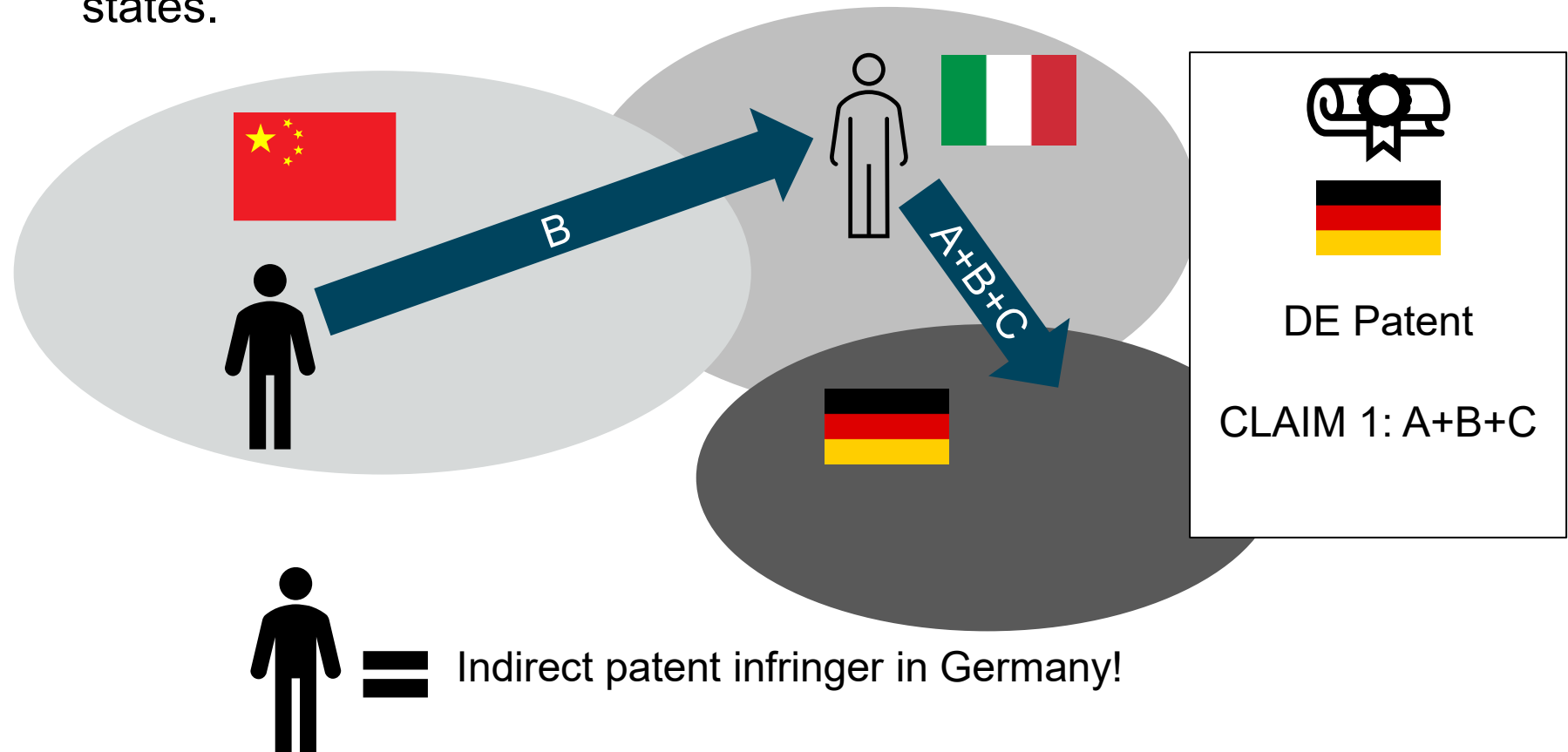

Cross-border contributory infringement

But there is contributory infringement of UP even if subsequent indirect infringement and supply take place in different UPC states.

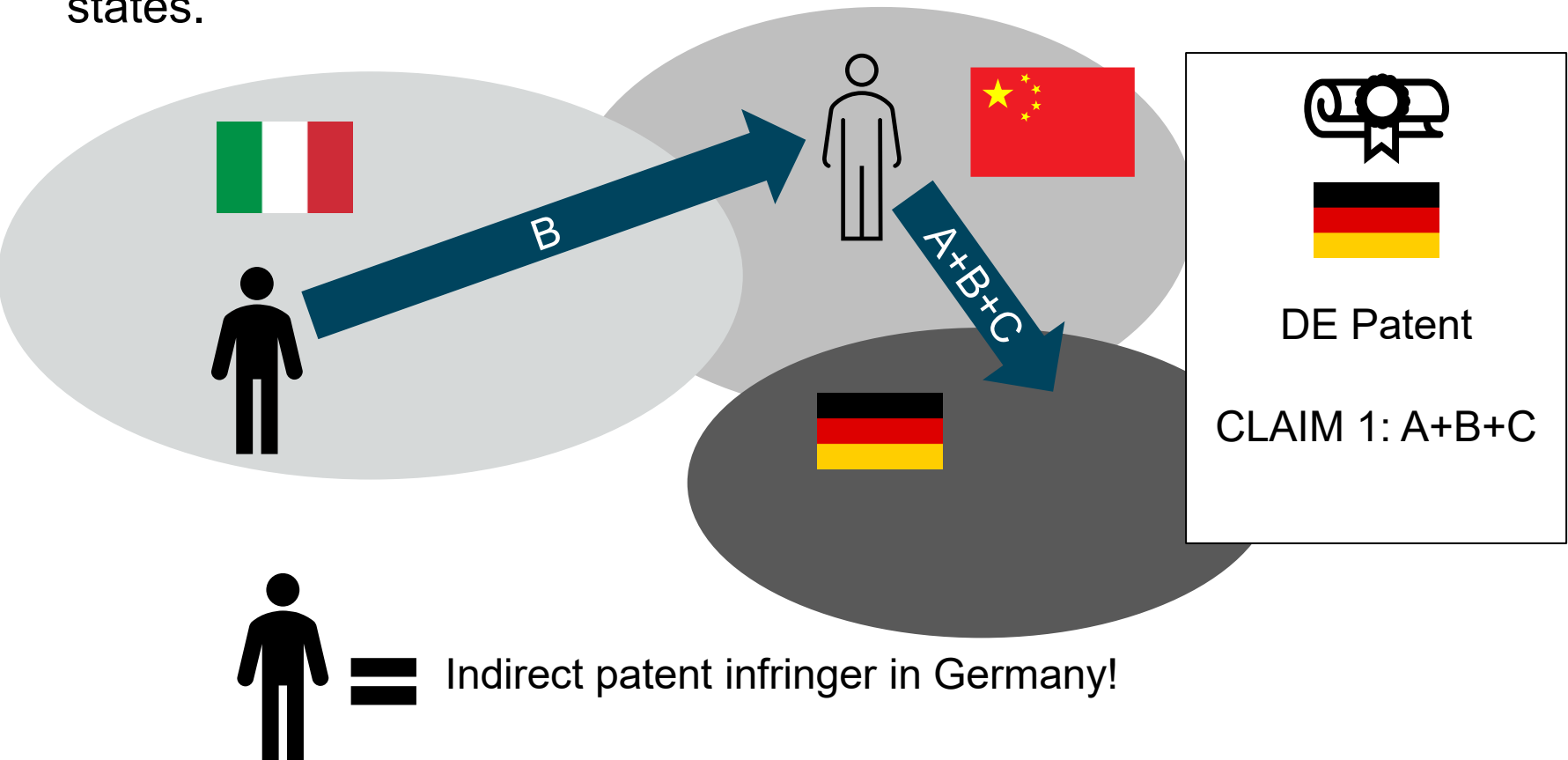

Cross-border contributory infringement

Choose wisely, keeping case law in mind!

Curiosity – The Spanish bug?

Spanish Patent Act, Section 60(1):

“La patente confiere igualmente a su titular el derecho a impedir que sin su consentimiento cualquier tercero entregue u ofrezca entregar medios para la puesta en práctica de la invención patentada relativos a un elemento esencial de la misma a personas no habilitadas para explotarla, cuando el tercero sabe o las circunstancias hacen evidente que tales medios son aptos para la puesta en práctica de la invención y están destinados a ella.”

Case law?

German patents for quick protection

Use national patent applications in Germany (Europe's biggest market economy):

1. As back-up for UP / non-opted-out EP
2. For additional/reliable protection in view of relevant case law
3. For quick protection/enforcement

Preliminary injunctions (PI)

PIs can be obtained and **enforced** very quickly in Germany by German authorities.

What about UPC-wide PIs? Equally rapid enforcement?

Double action prohibition does not apply to PIs (§ 18 IntPatÜG)!

Summary: when to patent in Germany

- European patent should be validated as UP despite possibly being weak, back.
- European patent covers key technology.
- If litigation is possible or in sight.
- If PI should be requested in Germany.
- To proceed against suppliers of competitors in Germany as contributory infringers.
- To act quickly, consider using UM (branch-off).

How is it done?

1. The PCT way

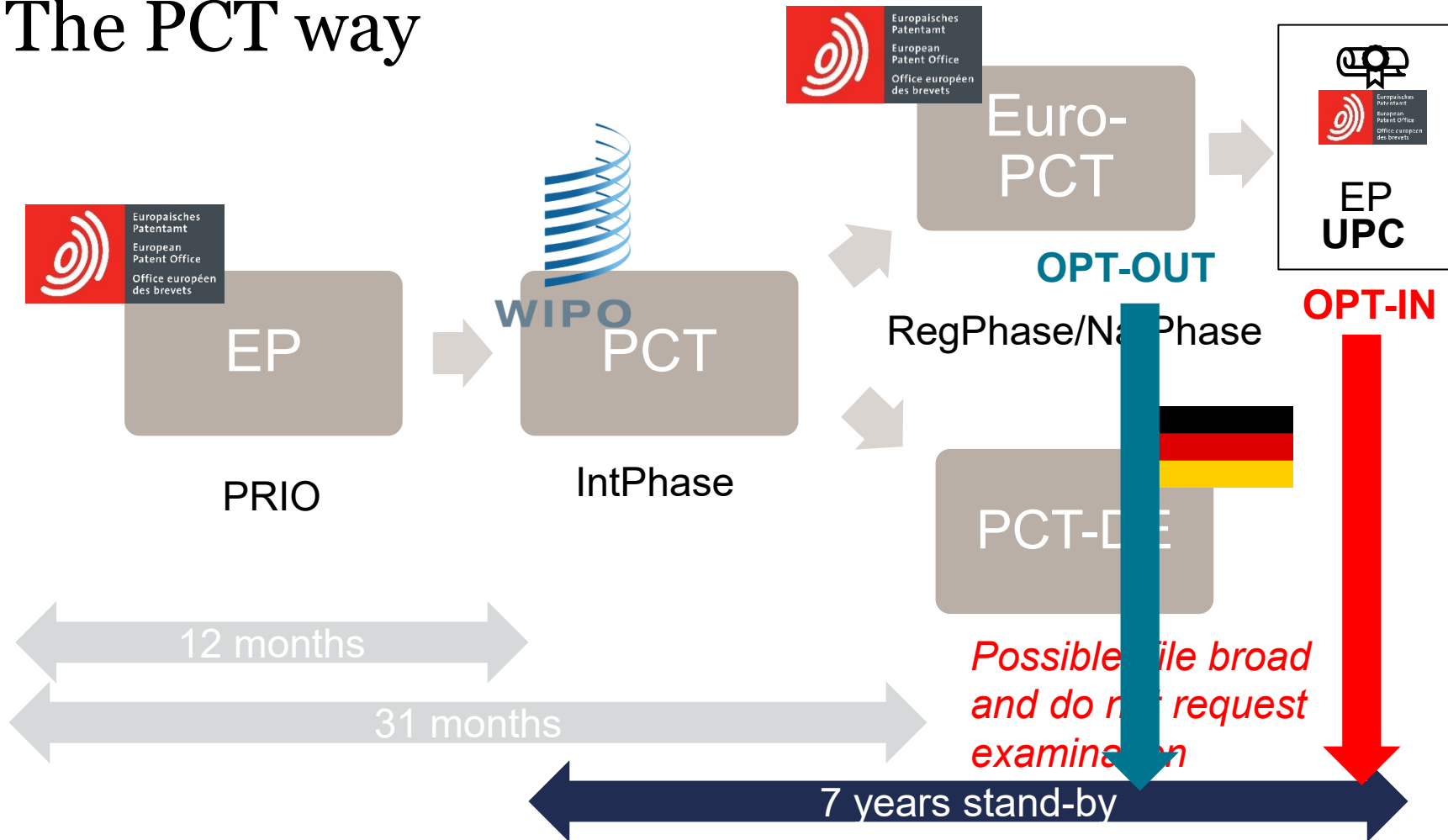

How is it done?

1. The PCT way

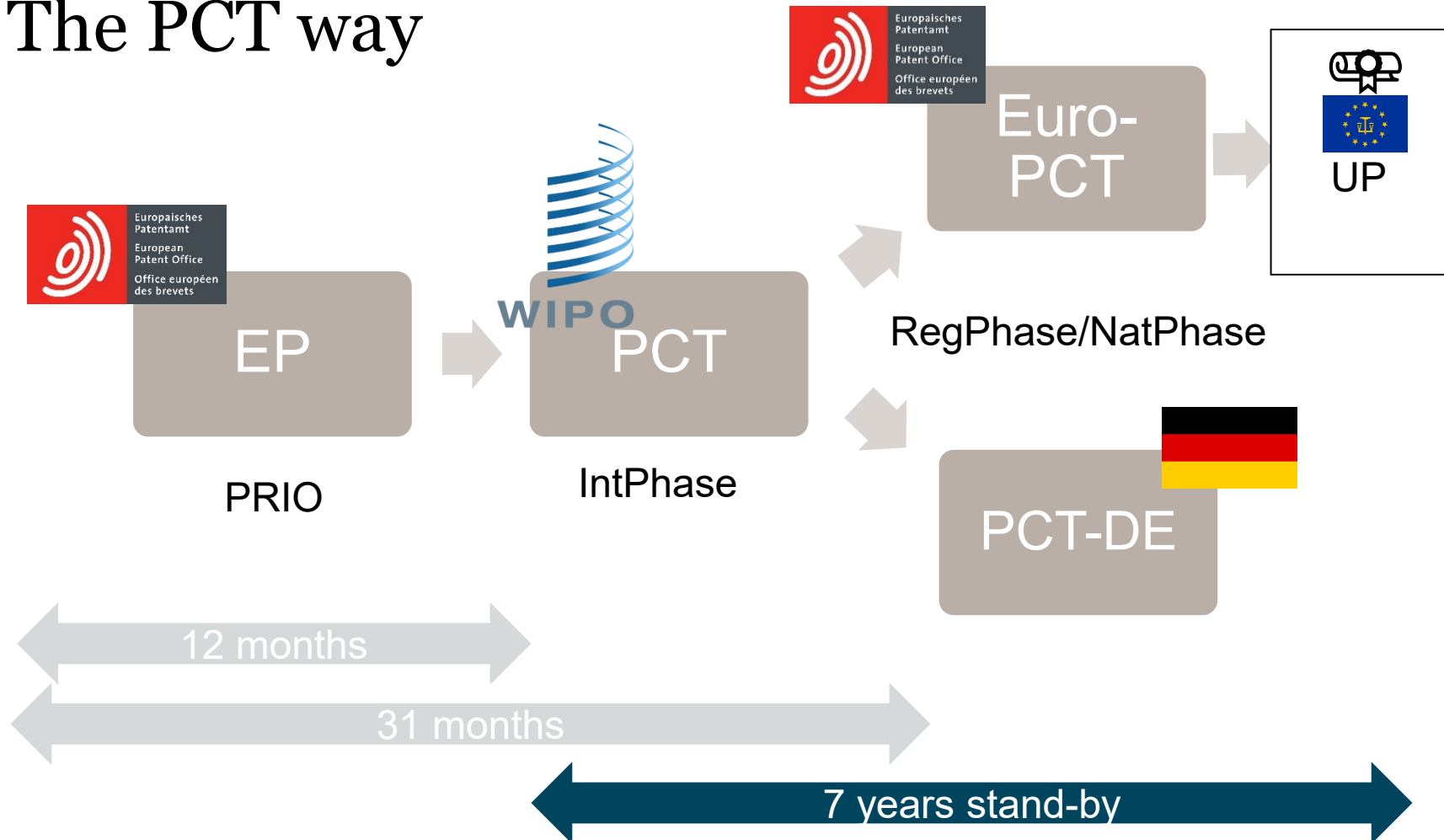

How is it done?

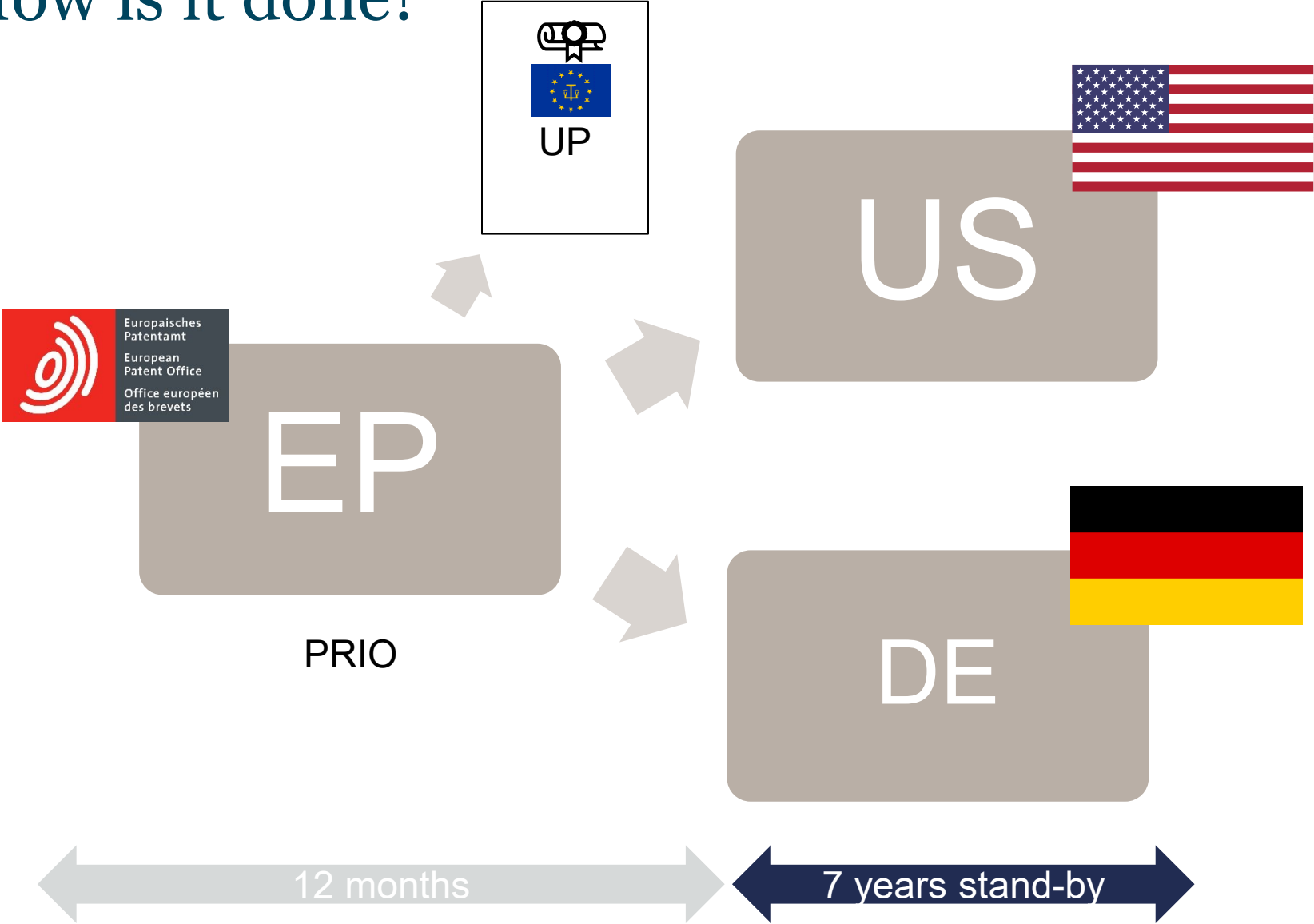

How is it done?

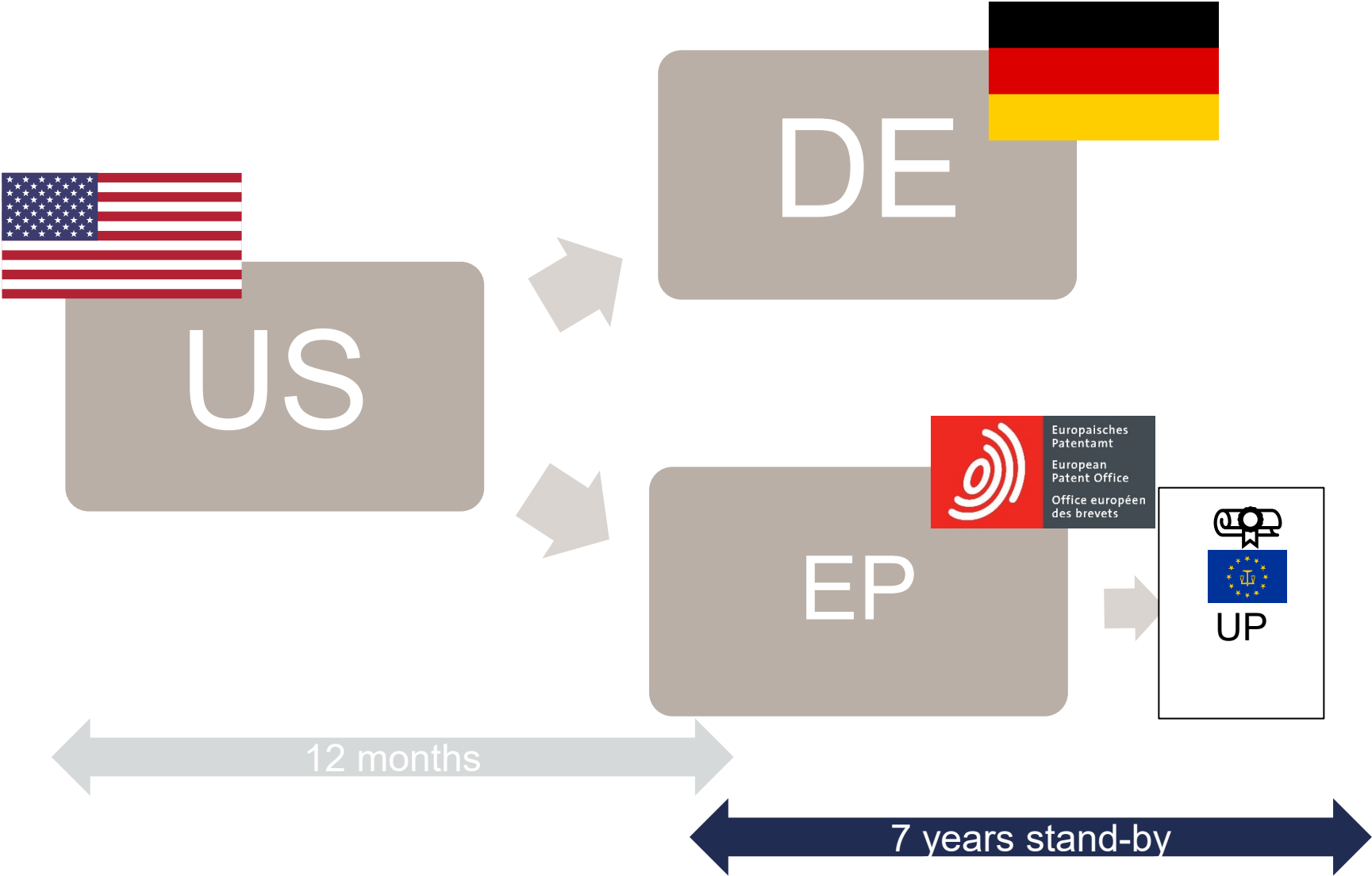

How is it done?

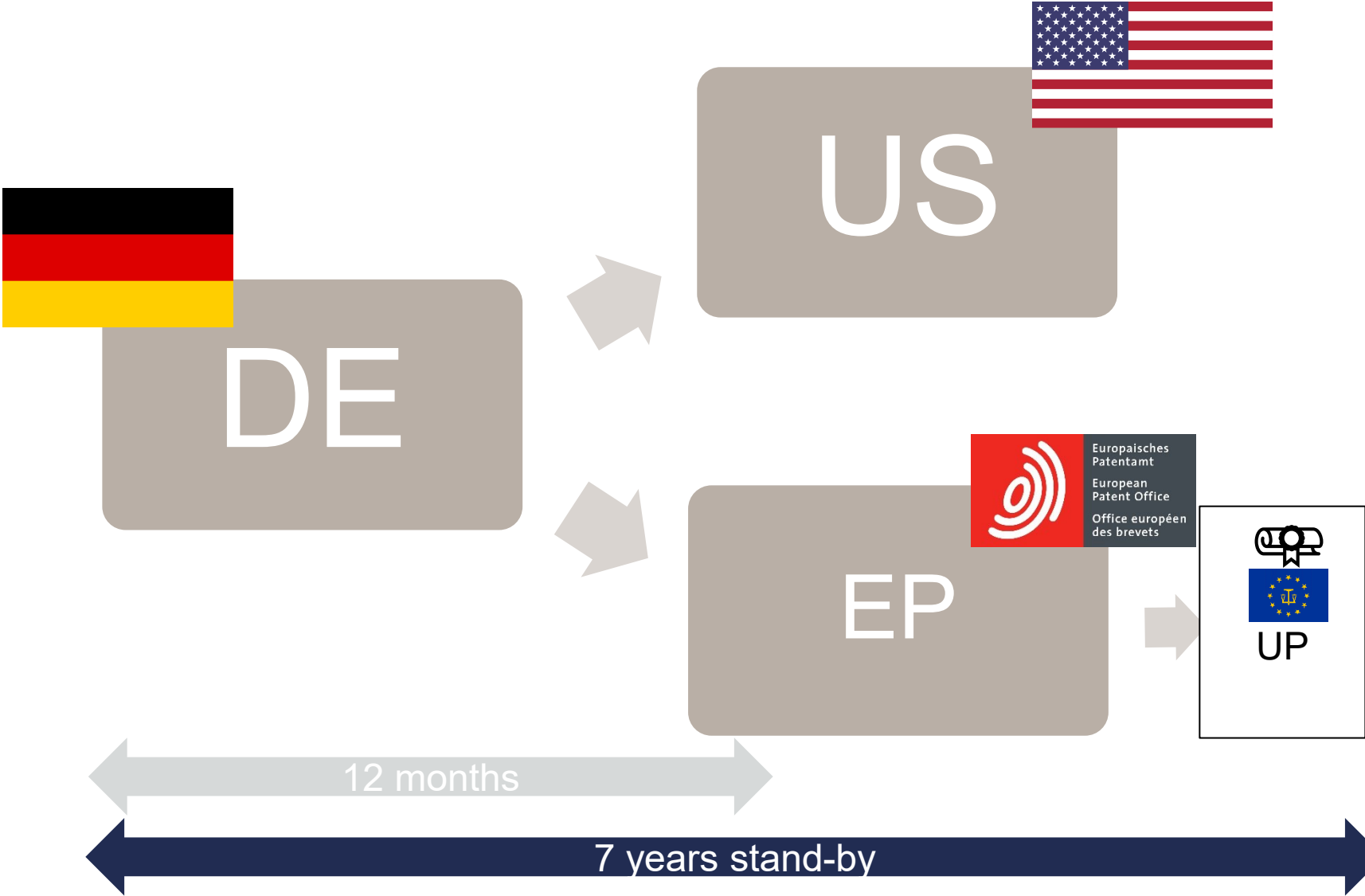

Summary: use DE + EP/UP

- Use possibility of keeping DE application in stand-by without examination (and without costs!) wisely.
- Consider entering national Phase in DE in parallel to EP (now!).
- Very cost effective flanking right for enhanced protection in greatest European market.
- Use DE to keep access to German national patent courts, even after expiry of transitional period of UPC.
- Strategically use infringement action in Germany to hit competitors and block European market.
- In some cases, national filings may replace EP filing.



Thank you for your kind attention.

Mario Araujo

araujo@boehmert.de

Boehmert & Boehmert

Pettenkoferstraße 22

80336 Munich

Germany

T +49-89-55 96 80

F +49-89-34 70 10